

User Manual



Phaser™ 220i and Phaser™ 220e Color Printers

Copyright © 1993 by Tektronix, Inc., Wilsonville, Oregon. Printed in the United States of America. All rights reserved. Contents of this publication may not be reproduced in any form without permission of Tektronix, Inc.

This instrument, in whole or in part, may be protected by one or more U.S. or foreign patents or patent applications. Information provided upon request from Tektronix, Inc., P.O. Box 1000, Wilsonville, Oregon 97070-1000.

If acquired subject to FAR or DFARS, the following shall apply:

- Unpublished — rights reserved under the copyright laws of the United States.
- Restricted Rights Legend — Use, duplication, or disclosures by the U.S. government is subject to restrictions as set forth in subparagraph (c)(1)(ii) of the Rights in Technical Data and Computer Software clause at DFARS 252.227-7013, or in subparagraph (c) (2) of the Commercial Computer Software – Restricted Rights clause at FAR 52.227-19, as applicable. Tektronix, Inc., P.O. Box 1000, Wilsonville, Oregon 97070-1000.

Tektronix[®] is a registered trademark of Tektronix, Inc. TekColor[™], ColorCoat[™], ColorStix[™] and Finelight[™] are trademarks of Tektronix, Inc. Phaser[™] is a trademark of Tektronix, Inc. for color printers and related products.

Adobe[™] and PostScript[™], and IntelliSelect[™] are trademarks of Adobe Systems, Incorporated which may be registered in certain jurisdictions.

Times[™], Helvetica[™] and Palatino[™] are trademarks of Linotype-Hell AG and/or its subsidiaries.

Other marks are trademarks or registered trademarks of the companies with which they are associated.

PANTONE[®]* Colors generated by the Phaser 220i and 220e Color Printers are four-color process simulations and may not match PANTONE-identified solid color standards. Use current PANTONE Color Reference Manuals for accurate colors.

PANTONE Color simulations are only obtainable on these products when driven by qualified Pantone-licensed software packages. Contact Pantone, Inc. for a current list of qualified licensees.

* Pantone, Inc.'s check-standard trademark for color reproduction and color reproduction materials.

© Pantone, Inc., 1988.

Users safety summary

Terms in manual: CAUTION Conditions that can result in damage to the product.
WARNING Conditions that can result in personal injury or loss of life.

Power source: Do not apply more than 250 volts RMS between the supply conductors or between either supply conductor and ground. Use only the specified power cord and connector. Refer to a qualified service technician for changes to the cord or connector.

Operation of product: Avoid electric shock by contacting a qualified service technician to replace fuses inside the product. Do not operate without the covers and panels properly installed. Do not operate in an atmosphere of explosive gases.

Safety instructions: Read all installation instructions carefully before you plug the product into a power source.

Terms on product: CAUTION A personal injury hazard exists that may not be apparent. For example, a panel may cover the hazardous area. Also applies to a hazard to property including the product itself.
DANGER A personal injury hazard exists in the area where you see the sign.

Care of product: Disconnect the power plug by pulling the plug, not the cord. Disconnect the power plug if the power cord or plug is frayed or otherwise damaged, if you spill anything into the case, if product is exposed to any excess moisture, if product is dropped or damaged, if you suspect that the product needs servicing or repair, and whenever you clean the product.

Ground the product: Plug the three-wire power cord (with grounding prong) into grounded AC outlets only. If necessary, contact a licensed electrician to install a properly grounded outlet.

Symbols as marked on product:

DANGER high voltage:



Protective ground (earth) terminal:



Use caution. Refer to the manual(s) for information:



WARNING: If the product loses the ground connection, usage of knobs and controls (and other conductive parts) can cause an electrical shock. Electrical product may be hazardous if misused.

Contents

- 1 Introduction
- 2 Getting Set Up
 - At a glance 2-1
 - Setting up the printer 2-2
 - What you get with your printer 2-2
 - Installing the optional lower tray assembly 2-4
 - Removing the packing material from inside the printer 2-6
 - Install the transfer roll 2-7
 - Adding paper or transparencies 2-8
 - Connecting the printer 2-12
 - Printer ports 2-12
 - LocalTalk connection 2-13
 - Connecting the printer to a single computer using LocalTalk 2-14
 - Parallel connection 2-15
 - Serial connection 2-16
 - Ethernet connection (Phaser 220i only) 2-18
 - Connecting the power and turning on the printer 2-19
 - Front panel at power-up 2-20
 - Rear panel at power-up 2-21
 - Sample prints 2-21
 - Startup page 2-22
 - When the printer is ready for operation 2-22
 - Installing a driver on your computer 2-23
 - Phaser 220 drivers and utilities diskettes 2-23
 - PC users 2-23
 - Microsoft Windows 2-23
 - DOS 2-25
 - Macintosh users 2-26
 - Other software requirements 2-26
 - Workstation users 2-27
 - Turning off the sample prints 2-27
 - Turning off the startup page 2-27

- Setting up PC ports (DOS) 2-28
 - Parallel port setup 2-28
 - Serial port setup 2-29
- What next? 2-30

3 Printing

- Printing from a Macintosh 3-1
- Printing from a PC (Windows) 3-3
- Printing from a PC (DOS) 3-4
- Printing from a workstation 3-5
- Margins and print area 3-6
 - Perforated paper and transparencies 3-6
 - Non-perforated plain paper 3-7
- Using two paper trays 3-8
- Selecting driver features 3-9
- Getting information on printing from specific applications 3-9
- Print modes 3-10
- Color correction 3-11
- Fonts 3-12
 - Resident typefaces (PostScript) 3-12
 - Resident typefaces (PCL5) 3-13
 - Downloading fonts 3-13
 - Font upgrade (Phaser 220e) 3-13
 - Installing Macintosh screen fonts 3-13
- Printer languages: PostScript, HP-GL, PCL5 3-14
 - Enabling and disabling automatic language switching 3-14
 - Printing with HP-GL 3-15
 - Changing the HP-GL default settings 3-15
- Printing hints 3-16
 - Getting the largest printed picture 3-16
 - Why should I use perforated paper? 3-16
 - How long does it take to make a print? 3-16
 - Which port is faster, parallel or serial? 3-16

4 Caring for Your Printer

Overview 4-1

Importance of cleaning 4-1

When to clean 4-2

Cleaning kit 4-3

Cleaning the printer (with every transfer roll change) 4-4

Cleaning the thermal head and transfer roll guide 4-4

Cleaning the paper-feed rollers 4-5

Cleaning the paper-pick rollers 4-6

Cleaning the printer (every 5000 prints) 4-10

Cleaning the transfer roll sensor pad 4-10

Cleaning the drum 4-12

Cleaning the exit rollers 4-13

5 Supplies

Always use Tektronix supplies 5-1

Ordering information 5-1

Supplies kits 5-1

Using plain paper 5-2

ColorCoat™ transfer roll 5-2

Use the correct paper tray for plain-paper printing 5-3

Plain-paper startup kit 5-3

Recommended paper types 5-4

Handling supplies 5-6

Removing a used transfer roll 5-7

6 Troubleshooting

Clearing transfer roll jams 6-1

Clearing paper jams 6-2

To remove paper from the drum: 6-3

Problems and solutions 6-5

If you can't make a print 6-5

Printer not operating 6-5

- Printer doesn't appear in the Chooser 6-7
- READY light blinks, but the file does not print 6-7
- MEDIA light blinks, and no print is produced 6-7
- Print job does not finish (the printer times out) 6-7
- Media problems 6-8
 - Frequent paper-picking errors 6-8
 - Frequent paper jams 6-8
 - You feel resistance when installing the paper tray 6-8
- Problems with image size and position 6-9
 - Off-set images 6-9
 - Cut-off images 6-9
 - Image prints over perforations 6-9
 - Margins are too big with perforated paper or transparencies 6-9
 - Image shifts or margins are incorrect (Macintosh) 6-9
- Print quality problems 6-10
 - Plain paper prints have dull, faded colors and significant dropout 6-10
 - Prints on thermal-transfer paper or transparencies have dull colors 6-10
 - Streaks or spots 6-10
 - Black-and-white instead of color 6-11
- Startup page prints even though it is disabled 6-12
- Generating the configuration page 6-13
- Whom to call for help 6-14
 - HAL — Highly Automated Library 6-14

7 Front and Rear Panels

- Rear panel (Phaser 220e) 7-1
 - Rear panel DIP switches (Phaser 220e) 7-2
- Rear panel (Phaser 220i) 7-3
 - Rear panel DIP switches (Phaser 220i) 7-4
- Front panel (Phaser 220i and Phaser 220e) 7-6

A Technical Notes

Printer ports A-1

Parallel port A-1

Serial port A-3

Serial port signals A-4

Specifications A-5

B Expanding Your Printing System

Upgrade kits B-1

Advantages of adding memory B-2

Adding a hard disk for font storage (Phaser 220i only) B-3

Compatible hard disks B-3

Requirements for adding a hard disk B-3

Connecting one disk B-5

Connecting multiple disks B-6

C Moving Your Printer

Changing the line voltage C-1

Repacking your printer C-2

D Regulatory Information

Canadian EMC (Electromagnetic Compatibility) regulatory standards D-1

Declaration of conformity D-2

FCC Class B device (for 115 VAC equipment) D-3

Material Safety Data Sheet D-4

Index

Introduction

The Tektronix Phaser 220i and Phaser 220e are thermal-wax color printers that provide superior quality A/Letter-size and A4-size color prints. Both printers provide color printing at speeds up to two pages per minute. Both printers are PANTONE Color approved and include TekColor imaging enhancements.

Both printers deliver 300 x 300 dots-per inch (dpi) color resolution in their default printing modes. A driver-selectable high-resolution printing mode gives you 600 x 300 dpi resolution for the sharpest, clearest thermal-wax prints imaginable.

An optional lower tray assembly is available for both printers; the optional lower tray assembly provides dual-tray printing capability. Printing from two trays allows you to have paper and transparencies ready for printing at all times without switching trays. You can also load the same media in both trays.

Phaser 220 printers can provide vivid color on common laser paper, coated thermal-transfer paper, and transparencies. A specially formulated transfer roll gives prints on standard laser paper the brilliant color quality previously available only with coated thermal-transfer papers.

By using Tektronix *perforated* paper and transparencies, you can print full A/Letter-size or A4-size images with ISO (International Standards Organization) margins (5 mm; 0.2 in.).

Phaser 220 printers work with Macintosh computers, IBM Personal Computers and compatibles, and various workstations. You can print from several computers at the same time because the Phaser 220 printers support simultaneous input through serial, parallel, and LocalTalk ports. With the Phaser 220i, an optional Ethernet interface provides Ethernet connectivity with EtherTalk and Novell NetWare protocols. The TCP/IP protocol is also available by purchasing an additional option.

The Phaser 220i also provides a SCSI (Small Computer System Interface) port, which allows you to attach an external hard disk for additional font storage.

Phaser 220 printers let you make color prints from a variety of software applications since they incorporate Adobe's PostScript Level 2 software (based on Adobe PostScript code revision 2013) and accept HP-GL (Hewlett-Packard Graphics Language) files. Also, the printer can accept monochrome PCL5 (Printer Command Language) files. The Phaser 220 printer interfaces can automatically switch between all of the three supported languages: PostScript, HP-GL, and PCL5.

The Phaser 220i has 39 resident PostScript fonts; the Phaser 220e has 17 resident PostScript fonts, upgradable to 39. Both printers have PCL5 fonts resident. The printers accept the following types of fonts:

- Adobe Type 1
- Adobe Type 3
- TrueType
- A variety of user-defined fonts

To order supplies such as paper, transparencies, or color transfer rolls, refer to the supplies information sheet that is shipped with the printer and contact your local dealer or, in the U.S.A., call Tektronix at **1-800-835-6100**.

Getting Set Up

At a glance

To install your printer, perform the steps listed here. The following pages provide detailed installation instructions. If you used the pictorial installation instructions, you have already performed Steps 1 and 2. Begin with Step 3; turn to “Installing a driver on your computer” on page 2-23.

- 1. Setting up the printer**
Putting all the pieces together: unpacking the printer and accessories, checking the inventory, removing the packing material, installing the optional lower tray assembly, loading the transfer roll, loading the paper tray(s), and setting the media switch for paper or transparencies.
- 2. Connecting the printer**
Connecting all necessary cables and turning on the printer.
- 3. Installing a driver on your computer**
Using the Phaser 220 driver diskettes to install a driver on your computer (Macintosh or Windows).
- 4. Turning off the sample prints and the start page**
- 5. Setting up serial or parallel computer ports (DOS)**

Note *For instructions for adding a hard disk to your printer, see “Adding a hard disk for font storage (Phaser 220i only)” on page B-3.*

Setting up the printer

What you get with your printer

1. Lower tray assembly (optional)
2. Paper tray(s)
3. Sample transfer roll
4. Power cord
5. Getting Started envelope
6. Cleaning kit
7. User manual
8. Supplies information sheet
9. Transparencies
10. Thermal-transfer paper
11. *Phaser 220 Drivers and Utilities Printing Reference manual*
12. Tektronix Phaser 220 drivers and utilities diskettes
13. *Network Utilities for Phaser Color Printers* (manual; optional with the Phaser 220i)
14. Tektronix network utilities diskettes (optional with the Phaser 220i)

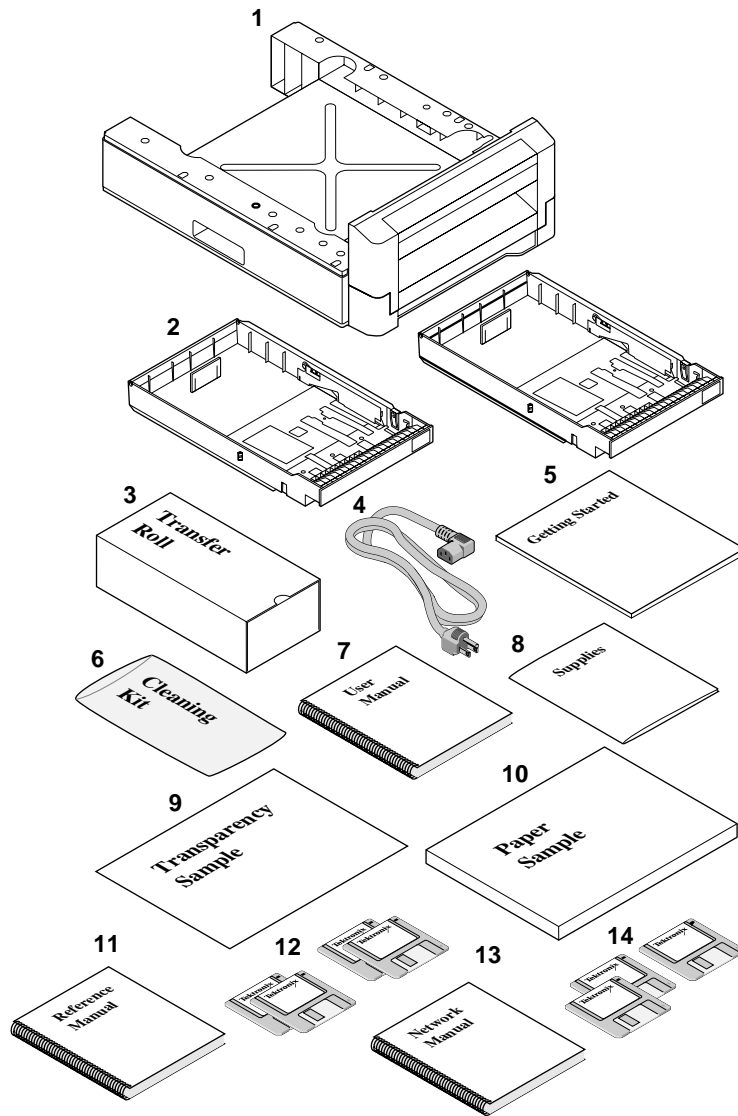

8869-2

Installing the optional lower tray assembly

An optional lower tray assembly is available with both Phaser 220 printers; with the optional lower tray assembly, you can print from two trays.

Note *The printer weighs about 18 kg. (40 lbs.). Observe standard precautions for lifting heavy objects.*

Warning *The printer is not permanently attached to the lower tray assembly. Take care to move the printer and lower tray assembly together by using the slots on the sides of the lower tray assembly. Moving the printer incorrectly may damage it and may cause personal injury.*

If you have a lower tray assembly, install it by performing these steps:

1. Place the printer on top of the lower tray assembly.
2. Make sure that the left and right alignment pins fit in the holes in the base of the printer.
3. Plug the lower tray assembly cable into the printer.
4. To move the printer, use the slots on either side of the lower tray assembly. Observe standard precautions for lifting heavy objects. To move the printer more than a few feet, it is easier to disconnect the lower tray assembly and move it separately from the printer.

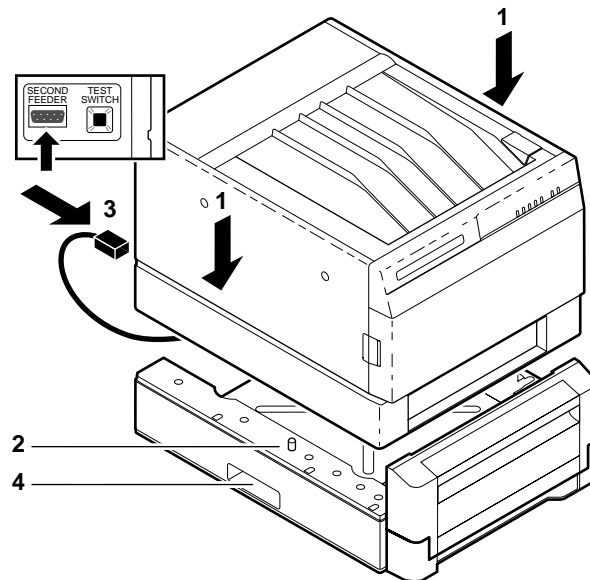

8869-18

Note When using a Phaser 220 with the optional lower tray assembly installed, make sure that the door covering the upper slot is closed. You cannot print from the lower tray with the door open.

Removing the packing material from inside the printer

1. Remove the packing tape from the top and front covers.
2. Press the button; open the top cover.
3. Remove the shipping material from the sides of the drum. (Keep all shipping material for storing or shipping the printer).

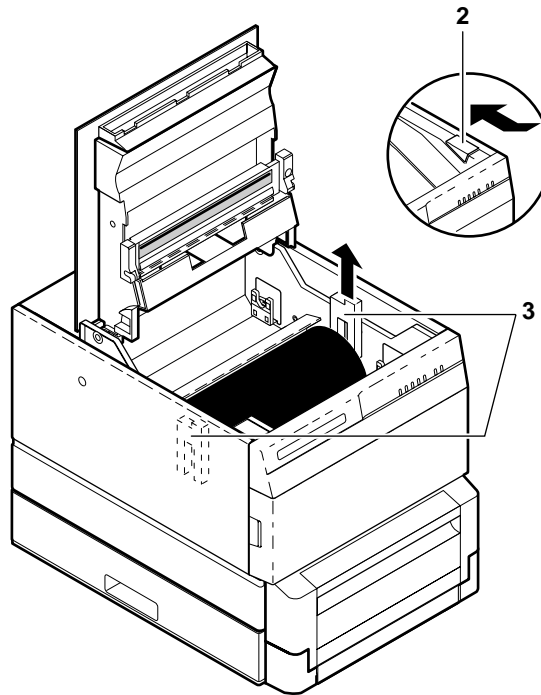

8869-3

Install the transfer roll

Note *ColorCoat transfer rolls are used with common laser paper; black and 3-color transfer rolls are used with Tektronix transparencies, thermal-transfer paper, and perforated premium laser paper.*

With the top cover still open, install the transfer roll:

1. Remove the transfer roll from the box. Remove the shipping foam from the transfer roll. Remove the foam clip from the full end of the roll.
2. Hold the transfer roll so that the black band on the roll is on your left.
3. With the black band on the roll to your left, place the empty end of the roll in the slots at the front of the printer.
4. Place the full end of the roll in the slots at the back of the printer.
5. Turn the full end of the roll to remove slack.
6. Close the cover.

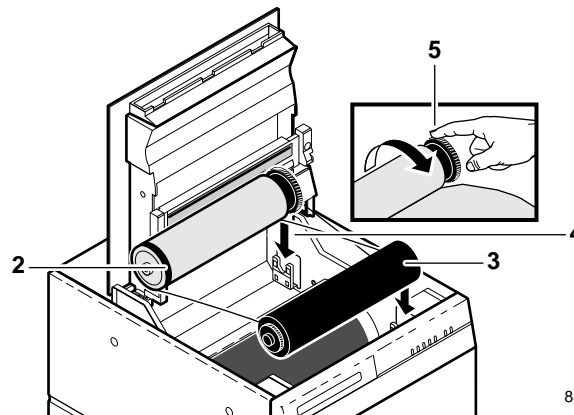

8869-19

Adding paper or transparencies

Unpack the paper tray. Be sure to remove all adhesive tape.

Note *The printer uses a different paper tray for each paper size (Letter, Letter-perforated, A4, A4-perforated). The trays are **not** adjustable.*

1. If you are using a tray for perforated paper or transparencies, set the selection switch on the tray (1) for paper or transparencies. Trays for non-perforated plain paper do not have this switch.

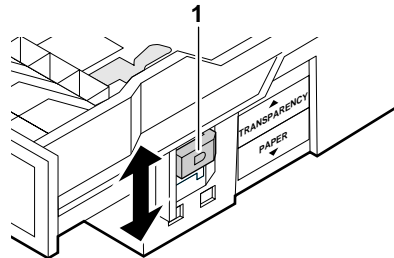

8869-20

2. Make sure that the metal plate is all the way down. If necessary, push the metal plate down until it clicks into place. Do not attempt to change the position of the vertical tab (3) at the back of the paper tray.

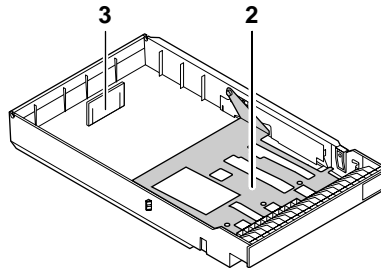

8869-12

3. Fan the paper or transparencies.

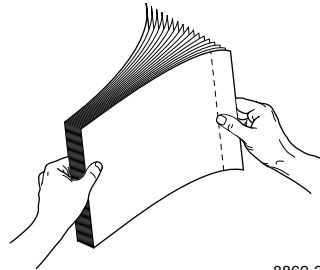

8869-21

4. Load perforated paper or transparencies with the perforations toward the front of the tray.
5. Place paper or transparencies in the tray under the hooks. Load transparencies with the film side up. Load thermal-transfer paper with the shiny side up (not applicable for plain paper).

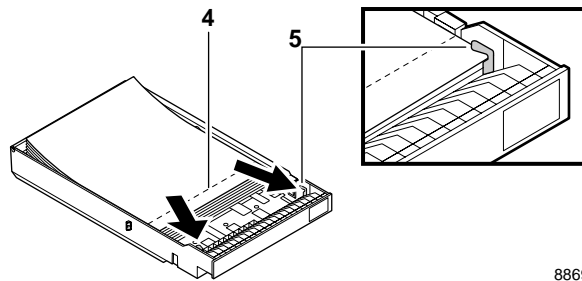

8869-22

2 Getting Set Up

6. If your printer has a single paper tray, push the paper tray into the slot.

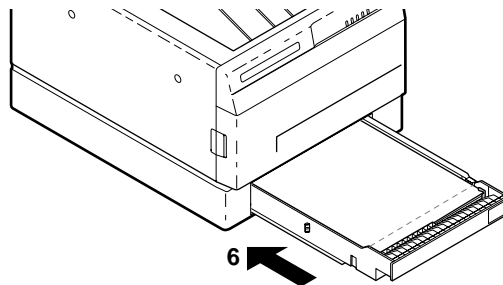

8869-23

7. If your printer has a lower tray assembly:
 - a. Install a tray in the lower slot.
 - b. Open the door to install a tray in the upper slot.

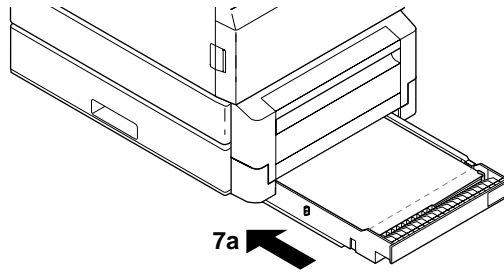

8869-4

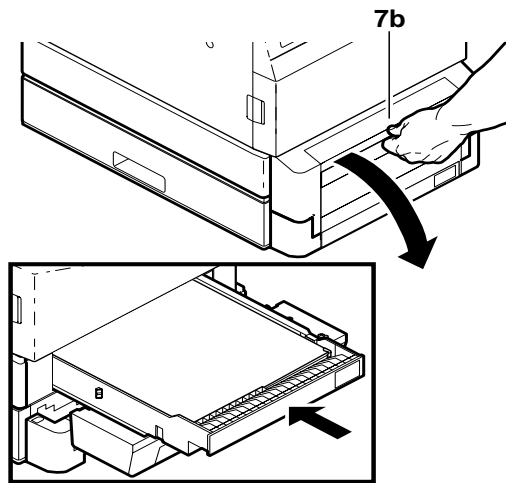

8869-5

Connecting the printer

Printer ports

Both the Phaser 220i and Phaser 220e printers accept data through these ports:

- LocalTalk
- Parallel
- Serial (RS-232)

The Phaser 220i has a SCSI port, which is used only for connecting an external hard disk. Refer to “Adding a hard disk for font storage (Phaser 220i only)” on page B-3 for more information on the SCSI port.

The Phaser 220i also has an Ethernet connector. An optional Ethernet interface is required to activate the connector. The optional Ethernet interface provides Ethernet connectivity with EtherTalk and Novell NetWare protocols. The TCP/IP protocol is also available by purchasing an additional option.

LocalTalk connection

You can make LocalTalk connections between the printer and a single computer or on a LocalTalk network using a *daisy-chain* setup. If your LocalTalk installation is complex, or if you need assistance, contact your network system administrator.

LocalTalk connectors and cables are available through your dealer. This illustration shows two commonly used types of LocalTalk connectors:

1. Self-terminating connector
2. Connector that requires an external terminator, depending on your network configuration

Note *Depending on the type of LocalTalk cables you use and your network configuration, you might need to use terminators at certain points in the installation. Refer to the documentation for your LocalTalk connectors and cables for details.*

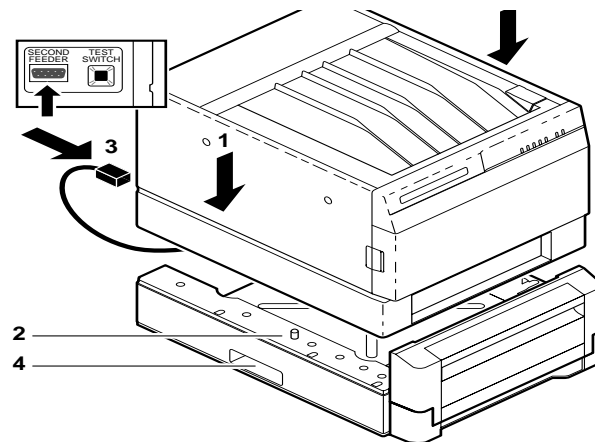

8869-18

Note *LocalTalk is sometimes referred to as AppleTalk. LocalTalk refers to the physical connection; AppleTalk is the protocol.*

Connecting the printer to a single computer using LocalTalk

You can use LocalTalk connectors and cables to connect the printer directly to your computer, without connecting it to any other network. Make sure that the printer is turned *off* before making any LocalTalk connections.

1. Connect the short cable of a LocalTalk connector to the printer's LocalTalk port.
2. Connect the short cable of another LocalTalk connector to your computer's LocalTalk port.
3. Connect a LocalTalk cable from the LocalTalk connector that you have just attached to your computer to the printer's LocalTalk connector.

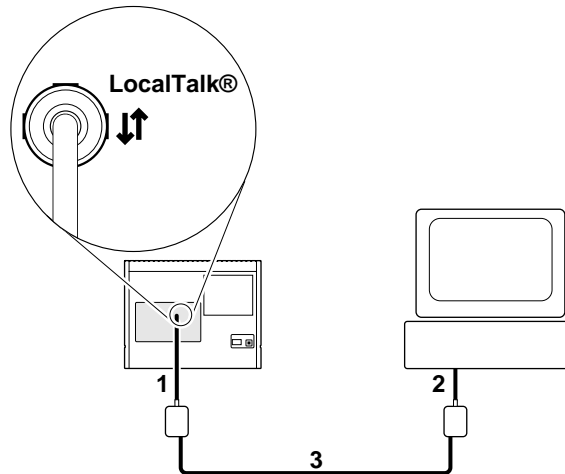

8869-24

For details on how to select the printer in the **Chooser**, change the printer's name, or set the printer's zone, refer to the manual *Phaser 220 Drivers and Utilities Printing Reference*. If you have no other connections to make, turn immediately to "Connecting the power and turning on the printer" on page 2-19.

Parallel connection

1. Connect a parallel interface cable to your computer and to the printer's parallel port.

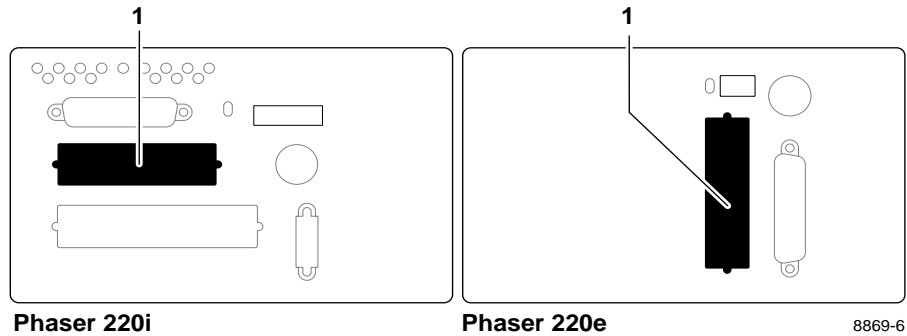

2. If you have no other connections to make, turn immediately to “Connecting the power and turning on the printer” on page 2-19. After you turn on the printer and install a driver on your computer, you may disable timeouts on your computer's parallel port (see “Setting up PC ports (DOS)” on page 2-28).

Serial connection

1. Connect a serial interface cable to your computer and to the printer's serial port. Use a null-modem cable (if you need to order a cable, see the supplies information sheet that is shipped with the printer).
2. Set the rear panel DIP switch(es) for the baud rate you want. The following table lists the switch settings.

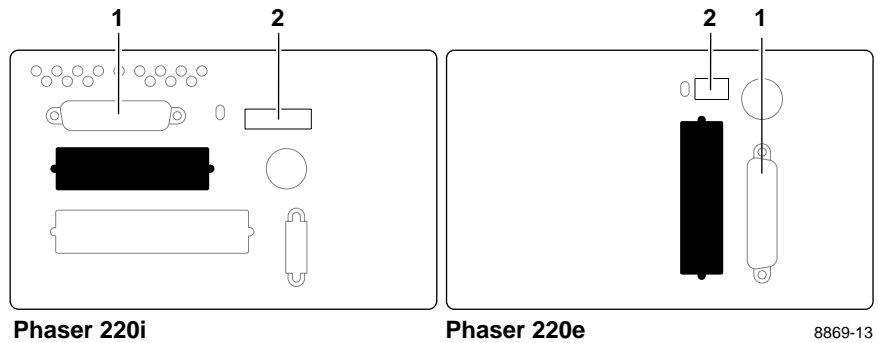

Baud rate settings for Phaser 220i and Phaser 220e

Printer	Baud rate	Switch setting
Phaser 220i	Variable, 9600 default	Switch 7 <i>down</i>
	Fixed, 1200	Switch 7 <i>up</i>
Phaser 220e	Variable, 9600 default	Setting Switches 2, 3, and 4 <i>down</i> enables the variable baud rate and sets other printer functions to default values. Refer to Chapter 7 for details on all printer functions affected by the rear panel DIP switches.
	Fixed, 1200	Switch 2 <i>up</i> , and switches 3 and 4 <i>down</i> . This setting also turns off color adjustment and sample prints. Refer to Chapter 7 for details on all printer functions affected by the rear panel DIP switches.

Note *With the serial port set for variable baud rate, the default baud rate is 9600, however, you can change the baud rate to a setting other than 9600. For details, refer to the manual Phaser 220 Drivers and Utilities Printing Reference.*

If you have no other connections to make, turn to the topic “Connecting the power and turning on the printer” on page 2-19. After you turn on the printer and install a driver on your computer, you must set up your computer's serial port to match the settings you have selected for the printer's serial port (see “Setting up PC ports (DOS)” on page 2-28).

Ethernet connection (Phaser 220i only)

Ethernet is a communication standard that supports very high speed data transmission. For complete information on installing the Phaser 220i on Ethernet networks, refer to the manual *Network Utilities for Phaser Color Printers*.

The Phaser 220e can be attached to Ethernet networks by using the Tektronix 4511A Network Interface. The 4511A Network Interface supports the TCP/IP protocol. See your authorized Tektronix representative for 4511A ordering information.

Note *For information on connecting your Phaser 220 in VMS environments, contact Tektronix Customer Support.*

Connecting the power and turning on the printer

1. Plug the power cord into the printer and into a grounded outlet.
2. Turn on the printer.

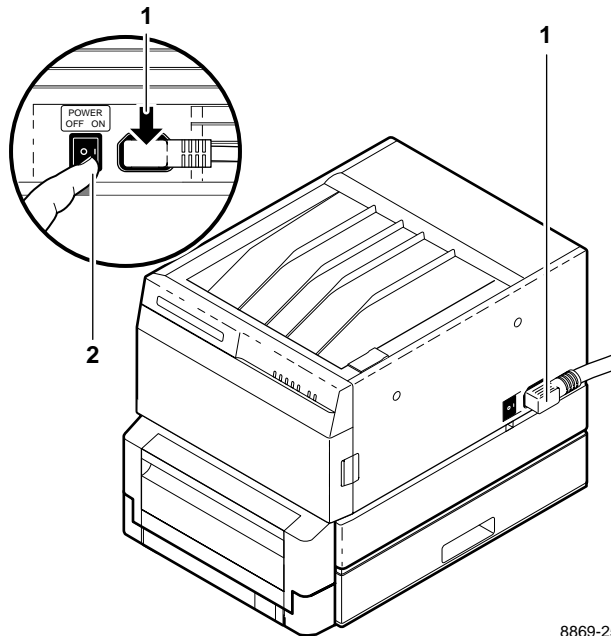

8869-25

When you turn on the printer, it executes a series of self-tests to determine if there are any problems. After running self-tests, the printer prints sample prints, if sample prints are enabled. (The factory default is to have sample prints enabled.) After running self-tests and printing the sample pages, the printer is ready for operation. The entire power-up sequence can last from 6 to 7 minutes, depending on the type of transfer roll installed and whether the sample pages are enabled. The next few topics describe the printer's power-up sequence in detail.

Front panel at power-up

All indicators light briefly and immediately go out, except **POWER** and **READY**, which remain on for about 10 seconds. Then the **READY** indicator blinks while the **POWER** indicator remains on and the self-tests are run. When both **POWER** and **READY** are on steady (not blinking), the self-tests are complete.

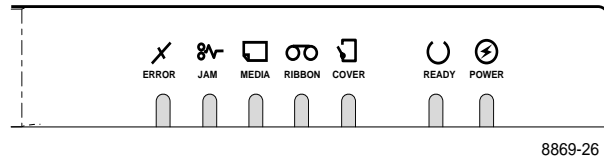

When a *standard transfer roll* is more than 75 percent used up, the front-panel **RIBBON** indicator lights, reminding you that it is time to order a new transfer roll.

When you install the *sample transfer roll* supplied with the printer, the **RIBBON** indicator may light as soon as you install it, or after you make a few prints. This is because the *sample transfer roll* contains a limited number of prints.

For complete information on the front-panel indicator lights, refer to “Front panel (Phaser 220i and Phaser 220e)” on page 7-6.

Rear panel at power-up

During the first 40 - 60 seconds of the power-up sequence, the rear-panel status indicator (1) goes on and off periodically. After about 40 - 60 seconds, the status indicator blinks continuously, indicating that the printer is ready for normal operation.

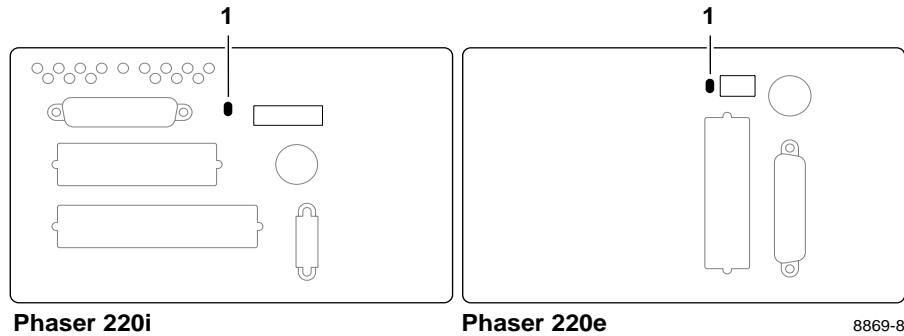

Sample prints

After the self-tests run successfully, the printer prints three sample prints, if the sample prints are enabled. These sample prints verify that the printer is ready for normal operation and show you the brilliant color you can get with the Phaser 220. The samples take about four minutes to print. The **READY** indicator blinks while the sample pages are printing.

When sample prints are enabled, the samples are printed whenever you turn on the printer. For details on how to disable the sample prints, see “Turning off the sample prints” on page 2-27.

Note *If the startup page is disabled, the sample prints do not print.*

Startup page

When sample prints are disabled, the printer produces a startup page after the self-tests run successfully, if the startup page is enabled. The printer takes from 15 to 45 seconds to print the startup page, depending on the type of transfer roll installed. The **READY** indicator blinks while the startup page is printing.

The startup page contains information on printer configuration and error messages. When enabled, the startup page prints whenever you turn on the printer. For details on how to disable the startup page, refer to the manual *Phaser 220 Drivers and Utilities Printing Reference*.

Note *After the startup page prints, a registration page prints if the printer has made between 6 and 8 prints since it was built. If you have not already registered your printer, please do so by filling out this page and sending it in.*

When the printer is ready for operation

When the power-up sequence is complete, both the **POWER** and **READY** indicators remain on, indicating that the printer is ready for operation.

Installing a driver on your computer

Phaser 220 drivers and utilities diskettes

Packaged with your printer are the Phaser 220 drivers and utilities diskettes for PC and Macintosh.

For complete details on the contents of the Phaser 220 drivers and utilities diskettes and how to use them, refer to the manual *Phaser 220 Drivers and Utilities Printing Reference*, which is shipped with the diskettes.

PC users

Microsoft Windows

The Phaser 220 diskettes include a Microsoft Windows 3.1 driver for this printer. If you want to use Microsoft Windows applications with this printer, install the driver onto your PC.

To install the Tektronix Windows 3.1 driver:

1. Start Windows on your PC.
2. Insert the Tektronix Windows 3.1 Printer Driver diskette into your computer's disk drive.
3. Open the **Control Panel**. Double-click the **Printers** icon; the **Printers** dialog box appears.
4. Choose the **Add** button.
5. In the **List of Printers**, select **Install Unlisted or Updated Printer**.
6. Choose the **Install** button.
7. Type in the drive that the PC diskette is in (for example, drive **B**) and click on the **OK** button.

8. Select your printer and click on **OK**.
9. The driver software you need is automatically installed.
10. Assign the printer to a port:
 - a. Select the printer from the list of installed printers.
 - b. Choose the **Connect** button to display the **Connect** dialog box.
 - c. Set the **Transmission Retry** value to **995**. Refer to your Windows documentation for details.
 - d. Select a port:

<u>Interface</u>	<u>Select</u>
Parallel	LPT1 or LPT2
Serial	COM1 or COM2
Network	Network button

If you selected a parallel port, go on to step e.

If you selected a serial port, click on the **Settings** button to open the **Settings** dialog box. Fill in each item according to your configuration, then click on **OK**. Refer to your Windows documentation for details or ask your network administrator for help.

If you clicked on the **Network** button, the **Printers – Network Connections** dialog box appears. Fill in each item according to your configuration. Refer to your Windows documentation for details or ask your network administrator for help.

Note *The printer's configuration page contains the information you need to set up the printer port. For information on generating a configuration page, see "Generating the configuration page" on page 6-13.*

- e. Click on **OK** in the **Connect** dialog box and close the **Printers** dialog box.

Note *If you are using Windows 3.1, you can use the Phaser 220 with the standard Microsoft Windows PostScript driver (with a WPD file). With the standard driver, you get the printer page size information, but you do not get color corrections and other PostScript Level 2 features; those features are only available through the Tektronix driver for Windows 3.1. For details on WPD files, refer to the manual **Phaser 220 Drivers and Utilities Printing Reference**.*

The manual *Phaser 220 Drivers and Utilities Printing Reference* provides a detailed driver installation procedure and complete information on using the Tektronix driver or the standard Windows PostScript driver with the printer.

DOS

Check the list of supported printers in your DOS application for support of the Phaser 220i or Phaser 220e. If the list does not include the Phaser 220i or Phaser 220e, use a generic color PostScript driver.

Macintosh users

Install the Phaser 220i or Phaser 220e driver onto your Macintosh to make the best use of the printer. Phaser 220i and Phaser 220e drivers allow you to select Tektronix Phaser page sizes, upper and lower paper trays, and color adjustments. The driver works under Macintosh system software versions 6.0.7, 7.0.x, and above.

To install the driver:

1. Before installing the driver, disable all virus protection software you may have running. Virus protection software interferes with the driver installation. Refer to the program's documentation for instructions.
2. Insert the Macintosh Printer Driver diskette into the disk drive.
3. Double-click on the **Installer** icon.
4. Follow the directions on the screen to complete the driver installation.

The manual *Phaser 220 Drivers and Utilities Printing Reference* provides a detailed driver installation procedure and complete information on using the Tektronix driver with the printer.

Other software requirements

In addition to installing the driver, you may also need to install application-specific files (such as PPDs or PDFs) for such applications as PageMaker and QuarkXpress. For complete software requirements, refer to the manual *Phaser 220 Drivers and Utilities Printing Reference*.

Workstation users

The files on the Phaser 220 utilities diskettes are in PC format and can be used by Unix workstations to control Tektronix printer features. They are also available through electronic mail (see the manual *Phaser 220 Drivers and Utilities Printing Reference* for details).

You can copy these files to your workstation as you would other PC-format files (log on as *root*, mount the drive, and use the **cp** command). For detailed information on using these utility files, refer to the *Phaser 220 Drivers and Utilities Printing Reference*.

Turning off the sample prints

To disable the sample prints, use the DIP switches on the printer's rear panel. Set Switches 2, 3, and 4 *down*.

When the sample prints are disabled, a startup page will print at power-up if the startup page is enabled.

Turning off the startup page

You can disable the startup page by sending a PostScript language file from the printer's utilities diskette to the printer. For details on how to disable the startup page, refer to the manual *Phaser 220 Drivers and Utilities Printing Reference*.

Even when the startup page is enabled, you can still keep it from printing by removing the paper tray(s) at power-up. Put the paper tray(s) back in after the **READY** light stops blinking.

Setting up PC ports (DOS)

Parallel port setup

If you are using the printer's parallel port, you should disable timeouts on your computer's parallel port. Disabling timeouts ensures that large files will print, even if data transmission is slow.

The DOS **MODE** command is used to disable timeouts on your computer's parallel port. Type this command at the DOS prompt (if LPT1 is not available, use LPT2):

```
MODE LPT1:.,P > NUL
```

See your DOS documentation for details on the **MODE** command.

You may want to add the **MODE** command to your *AUTOEXEC.BAT* file, so that it takes effect every time you turn on your computer.

Serial port setup

If you are using the serial port, you must set up your computer's serial port parameters to match the way you set the printer's serial port parameters.

Under DOS, use the **MODE** command to set up your computer's serial port:

- If you set up the printer's serial port for variable baud rate and you are using the default serial parameters for this position, type this command at the DOS prompt (if COM1 is not available, use COM2):

MODE COM1:9600,N,8,1,P

If you changed the printer's serial port parameters from the default values, you must enter different values for the **MODE** command (see your DOS documentation for details on the **MODE** command).

- If you set up the printer's serial port for a fixed baud rate of 1200, type this command at the DOS prompt (if COM1 is not available, use COM2):

MODE COM1:1200,N,8,1,P

For a complete listing of the printer's default serial port parameters, see "Serial port" on page A-3.

You may want to add the **MODE** command to your *AUTOEXEC.BAT* file, so that it takes effect every time you turn on your computer.

What next?

- Once you have set up all the hardware and connectors, installed the software on your computer, and turned on the power, you are ready to print. Chapter 3, “Printing,” contains useful information on printing features such as color adjustment, fonts, and printing hints. For detailed information on printing options, refer to *Phaser 220 Drivers and Utilities Printing Reference*.
- To install a hard disk for font storage, turn to “Adding a hard disk for font storage (Phaser 220i only)” on page B-3.

Printing

Printing from a Macintosh

1. Make sure that the Tektronix printer driver for the Macintosh has been installed.
2. Select the driver:
 - a. Select **Chooser** from the Apple menu.
 - b. Select the Tektronix driver by clicking on the **Phaser 220** printer icon. (If it did not appear in the list of drivers, restart your Macintosh and repeat the driver installation procedure.)

A list of printers available in the current zone appears.

- c. Select the zone where your Phaser 220 is connected.
- d. Select the printer by name (default is **Phaser 220i** or **Phaser 220e**).

You can change the default with the *LaserWriter Utility*, which is on the drivers and utilities diskettes. See the *Phaser 220 Drivers and Utilities Printing Reference* for instructions.

3. To print a file, use the **Page Setup** and **Print** commands from the **File** menu within your application:
 - a. In the **Page Setup** dialog box, select the desired Tektronix paper size so that the application uses the correct margins for the printer. To see the Tektronix paper sizes in the **Page Setup** dialog box, use the pop-up menu to the right of the standard LaserWriter page sizes.
 - b. Click the **TekColor** button in the **Print** dialog box to open the **TekColor Options** dialog box, in which you can select TekColor color corrections, print quality (**Standard**, **Enhanced**, **High-resolution**), and paper trays (**Upper**, **Lower**, **AutoSelect**). For more details on the driver, refer to *Phaser 220 Drivers and Utilities Printing Reference*.

Printing from a PC (Windows)

1. Make sure that the Windows printer driver has been installed.
2. Click on the **Printer Setup** command from the **File** menu (or the similar command in your application). Select **Tek Phaser 220 (TekColor)** from the list. If you have previously set the printer as the default printer, it will already be selected on the list.
3. Use the **Setup** dialog box to select the paper size, paper source (**Upper tray, Lower tray, or Auto Select**), and other printing options.
4. Click on the **Options** button to display the **Options** dialog box. Then, click on the **Printer Features** button to display the **Tektronix Printer Features** dialog box. Use the **Tektronix Printer Features** dialog box to select TekColor color corrections and print quality (**Standard, Enhanced, High-resolution**). If the **Printer Features** button does not appear in the **Options** dialog box, the Tektronix Windows driver probably is not installed or the Phaser 220 has not been selected.

For details on the Tektronix driver, refer to *Phaser 220 Drivers and Utilities Printing Reference*.

Printing from a PC (DOS)

1. Set up the printing options in your application software for a color printer driver and a communications port. Refer to your application software user manual for details on how to make these selections.
2. Select the printer driver for the Phaser 220i or Phaser 220e, or a general color PostScript driver.
 - a. Select an LPT port if you have the printer connected to the parallel port, or select a COM port if you have the printer connected to the serial port.
 - b. Set the page margins in your application software as needed. For details on the printer's paper and margin sizes, refer to "Margins and print area" on page 3-6.
3. Execute the application software's print command. Refer to the software's user manual for details.

Printing from a workstation

You send files to this printer as you would any PostScript printer such as the Apple LaserWriter II NTX. Workstation users can print from any application that generates PostScript (Level 1 or 2), HP-GL, or PCL5.

Sun and SGI users can use Tektronix' Unix Phaser Print software with Tektronix color printers. Phaser Print provides fast raster screen copy printing to Tektronix color printers. Phaser Print also provides a graphical user interface for push-button control of certain Tektronix printer features.

Unix Phaser Print for Sun works with **lpr** to print PostScript files and raster files in these formats: Sun Raster Format (SRF), **xwd**, and SGI/RGB.

Unix Phaser Print for SGI works with **lp** to print ASCII text files, PostScript files, and raster files in these formats: SGI/RGB and **xwd**. Unix Phaser Print for SGI requires the Impresario printing software from SGI.

For more information on setting up spooling systems and printing from workstations, contact HAL, the Tektronix automated FAX system. Refer to "Whom to call for help" on page 6-14 for details on using the HAL system.

Margins and print area

When the printer places an image on paper, the image is a bit smaller than the paper size. You may need to adjust the page margins in your application software to match the print area.

Perforated paper and transparencies

Use Tektronix perforated paper or transparencies and the Tektronix Phaser 220i or Phaser 220e driver to get the largest image areas. With Tektronix perforated paper or transparencies, you can print the largest area and tear off the excess at the perforation. This gives full A or A-4 Letter-size images within ISO margins.

This illustration shows the largest image areas for perforated paper and transparencies. All margins are 5 mm (0.2 in.). The bottom margin is 5 mm (0.2 in) after the perforated area is removed.

1. American A-size (LETTER PERF)
2. Metric A4-size (A4 PERF)

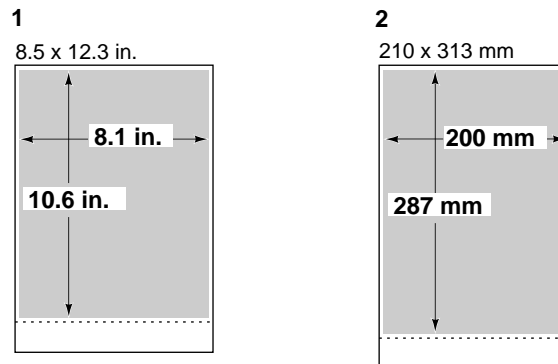

8869-27

Non-perforated plain paper

This illustration shows the largest image areas for non-perforated plain paper. All margins are 5 mm (0.2 in.), except the bottom margin (21 mm for A4-size, 0.83 in. for A-size).

Note *The standard trays supplied with the printer are for Tektronix perforated paper and transparencies; they are not adjustable for plain paper. Trays for plain paper must be ordered separately.*

1. American A-size (LETTER)
2. Metric A4-size (A4)

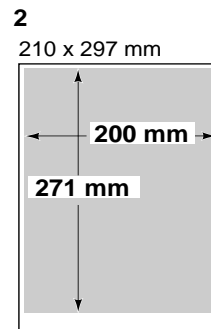
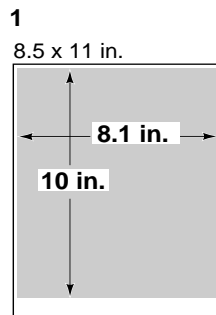

8869-28

Using two paper trays

Note *When using a printer with a lower tray assembly, make sure that the door covering the upper slot is closed before you try to make a print from the lower tray. You cannot print from the lower tray with the door open.*

Recommended paper tray selections

Use	If
Upper or Lower tray	You use different media in each tray or different sizes in each tray. Some examples: <ul style="list-style-type: none"> ■ Paper in one tray and transparency in the other. ■ Standard paper in one tray and special letterhead in the other. ■ Perforated paper in one tray and non-perforated in the other.
AutoSelect	You use the same media in both trays.

You can select the **Upper** or **Lower** tray by using a Tektronix Phaser 220 driver or a PostScript language file provided on the printer's utility diskettes. If you select the upper or lower tray by one of these methods, the printer will pick paper from the selected tray until the tray is empty. When the tray is empty, printing stops until the selected tray is filled, or until you select the other tray.

You can also select **AutoSelect** by using a Tektronix Phaser 220 driver or a PostScript language file provided on the printer's utility diskettes. If you select **AutoSelect** by one of these methods, the printer will pick paper from the tray that contains the selected paper size. When that tray is empty, the printer will automatically pick from the other tray if it also contains the selected media size.

Note *Paper tray selections made in the driver take priority over selections made by sending PostScript files to the printer.*

In all cases, you can change the printer's tray-switching behavior by sending the appropriate PostScript language file to the printer. For more information, see the manual *Phaser 220 Drivers and Utilities Printing Reference*.

Selecting driver features

You can use the Phaser 220i or Phaser 220e drivers to select Phaser 220 features:

- Page sizes
- Paper tray
- Color adjustments
- Print modes

For complete instructions on installing and using the Phaser 220 drivers, see the manual *Phaser 220 Drivers and Utilities Printing Reference*.

Getting information on printing from specific applications

You can get information on printing from specific applications by contacting HAL, the Tektronix automated information system. HAL faxes you information immediately on applications and other topics. For complete information on HAL, see “Whom to call for help” on page 6-14.

Print modes

The printer has three driver-selectable print modes:

- **Standard** mode is the default. It provides high-quality 300 x 300 dpi prints with the fastest print time.
- **Enhanced** mode provides improved 300 x 300 dpi prints; print time is increased by 10 seconds over **Standard** mode.
- **High-resolution** mode provides exceptionally high-quality 600 x 300 dpi prints. In **High-resolution** mode, image processing time is about 30% longer than with **Standard** mode. Also, the printer's *paper-marking* speed can be up to twice as long as **Standard** mode. (The paper-marking speed is the time it takes the printer to put the colored wax on the paper after it has processed the image).

Color correction

There are several ways to correct colors on your prints:

- **Using a printer driver or a utility file.**

For details on making color corrections through a printer driver or a utility file, refer to *Phaser 220 Drivers and Utilities Printing Reference*.

- **Using the color correction switches on the printer's rear panel.**

The Phaser 220 allows you to make color corrections using the printer's rear-panel DIP switches. For specific information on DIP switch settings, see Chapter 7.

Using the rear panel switches for color correction is only necessary if you are not set up to use the Phaser 220 drivers. If you are using TekColor Dynamic Correction in the Phaser 220 drivers, the settings you choose in the drivers override the rear panel switches.

For complete information on color correction, refer to *Phaser 220 Drivers and Utilities Printing Reference*.

Fonts

Resident typefaces (PostScript)

The standard Phaser 220i supports all typefaces shown. The Phaser 220e ships with 17 fonts; additional fonts can be added by adding Option 1F or the equivalent upgrade kit, 4680F1F.

1. Resident typefaces for Phaser 220e without Option 1F.
2. Additional resident typefaces provided with Phaser 220e Option 1F.

1	2
Courier Courier Bold <i>Courier Oblique</i> Courier Bold Oblique	ITC Avant Garde Gothic Book <i>ITC Avant Garde Gothic Book Oblique</i> ITC Avant Garde Gothic Demi <i>ITC Avant Garde Gothic Demi Oblique</i>
Helvetica Helvetica Bold <i>Helvetica Oblique</i> Helvetica Bold Oblique	ITC Bookman Light <i>ITC Bookman Light Italic</i> ITC Bookman Demi ITC Bookman Demi Italic
Helvetica Narrow Helvetica Narrow Bold <i>Helvetica Narrow Oblique</i> Helvetica Narrow Bold Oblique	Helvetica Condensed Helvetica Condensed Bold <i>Helvetica Condensed Oblique</i> Helvetica Condensed Bold Oblique
Times Roman Times Bold <i>Times Italic</i> Times Bold Italic	New Century Schoolbook New Century Schoolbook Bold <i>New Century Schoolbook Italic</i> New Century Schoolbook Bold Italic
Symbol (Σ ψ μ β ο λ)	Palatino <i>Palatino Italic</i> Palatino Bold Palatino Bold Italic
	<i>ITC Zapf Chancery</i> ITC Zapf Dingbats (☆ * ✕ ☼ ☼ ☼ ☼)
	8869-29

Resident typefaces (PCL5)

In PCL5 mode (HP LaserJet III emulation), the printer supports Courier, Times, and Universe typefaces in the following styles and stroke weights: medium, bold, italic medium, and bold italic.

Downloading fonts

The printer accepts Type 1, Type 3, and TrueType downloadable fonts including those from Adobe, AGFA, Bitstream, and many others. TrueType fonts are scalable to any point size and look the same on the screen as they do when printed.

If you have an external hard disk connected to the Phaser 220i, you can store the downloadable fonts on it. You can use utilities on the Phaser 220 printer utilities diskettes to download fonts to the printer. For details, see the manual *Phaser 220 Drivers and Utilities Printing Reference*.

Font upgrade (Phaser 220e)

You can upgrade the Phaser 220e to 39 resident fonts (the same as the Phaser 220i). The font SIMM for this upgrade is available as Option 1F or upgrade kit 4680F1F.

Installing Macintosh screen fonts

Phaser 220 Macintosh diskettes include screen fonts for these typeface families: Times, Helvetica, Courier, Symbol, Helvetica Condensed, Helvetica Narrow, Palatino, ITC Avant Garde Gothic, ITC Bookman, ITC Zapf Chancery, ITC Zapf Dingbats, and New Century Schoolbook.

If they are not already installed, you must install these screen fonts if you want to see the printer's resident typefaces on the Macintosh screen. For information on how to install fonts, see the *Phaser 220 Drivers and Utilities Printing Reference* or your Macintosh documentation.

Printer languages: PostScript, HP-GL, PCL5

With Adobe IntelliSelect™ technology, Phaser 220 printers can automatically sense the language of the print job and process it accordingly. This is called *automatic language selection*. You can also set up any printer port to receive one language only. If you set up a port to receive a particular language only, the port will only accept jobs of that type. The printer reports an error if another language is sent to that port.

The following table shows the default language setting for each port.

Default printer port settings

Port	Language
Serial	PostScript
Parallel	PostScript
LocalTalk	PostScript
EtherTalk	PostScript
LPR	PostScript
AppSocket	Automatic language switching
NetWare	Automatic language switching

Enabling and disabling automatic language switching

To enable or disable automatic language selection on a port, send the appropriate PostScript language file to the printer. For more information, see the manual *Phaser 220 Drivers and Utilities Printing Reference*.

Printing with HP-GL

1. Use automatic language selection or change the printer port's language from PostScript to HP-GL.
2. Set up the printing options in your application by selecting a printer driver that supports the 7475A plotter.
3. Print from your application as usual.

Changing the HP-GL default settings

The printer has default values for the HP-GL parameters, such as pen color and pen width. When you turn the printer off and on (or reset it), the HP-GL values return to their default settings.

HP-GL default settings

Parameter	Default setting
Image scaling	To paper size
Timeout interval	15 seconds
Pen width	0.35 mm
Pen colors:	
Pen 1	Black
Pen 2	Red
Pen 3	Green
Pen 4	Blue
Pen 5	Cyan
Pen 6	Magenta
Pen 7	Yellow
Background color	White (pen number 0)

To change the values, send a PostScript language file to the printer. For details, refer to the manual *Phaser 220 Drivers and Utilities Printing Reference*.

Printing hints

Getting the largest printed picture

Use the Tektronix Phaser 220i or Phaser 220e driver and perforated paper or transparencies to get the largest print areas. You may also have to adjust the margins in your application software.

Why should I use perforated paper?

By using Tektronix perforated paper (and transparencies), you can print full A-size or A4-size images with standard ISO margins (5 mm; 0.2 in.).

How long does it take to make a print?

The total print time depends on the image complexity, the type of port used, and the printer's paper-marking speed. The paper-marking speed is the time it takes the printer to put the colored wax on the paper, once it has received the processed image.

Of these three elements, only the printer's paper-marking speed is predictable; the others can vary greatly depending on your system configuration and the type of image you are printing. However, the Phaser 220 PostScript interpreter combines very fast image processing and communication with sophisticated memory management to keep the total print time to a minimum. For details on the printer's paper-marking speed, see "Specifications" on page A-5.

Which port is faster, parallel or serial?

The parallel port is generally faster than the serial port.

Caring for Your Printer

Overview

To ensure the best print quality and the most reliable printer operation, follow these two simple guidelines:

- Use *only* Tektronix transparencies and transfer rolls. When printing with a 3-color or black transfer roll, use *only* Tektronix thermal-transfer paper. When printing with a ColorCoat transfer roll on common laser paper, use paper that conforms to the guidelines given in “Recommended paper types” on page 5-4.
- Perform the regular cleaning described in this chapter.

Importance of cleaning

By performing regular cleaning, you can ensure that your printer produces the highest quality prints. Regular cleaning also helps prevent paper jams, smudged prints, skewed images, and misregistration. If you clean the printer at intervals listed under the next topic, “When to clean,” you will experience fewer paper problems, improved print quality, and less downtime.

Cleaning the printer is easy. Follow the cleaning procedures given in the next few pages, or use the *Cleaning Instructions* that come with each cleaning kit.

When to clean

Every time you replace the transfer roll, clean these printer parts:

- Thermal head and transfer roll guide
- Paper-feed rollers
- Paper-pick rollers

Clean these printer parts every 5,000 prints, or as needed to prevent smudging on prints:

- Transfer roll sensor pad
- Drum
- Exit rollers

A preventive check by a Tektronix field service representative is recommended every 10,000 prints or every year. The startup page and the configuration page report the number of prints made since the printer was shipped from Tektronix.

Cleaning kit

A cleaning kit comes with the printer. The cleaning kit contains these items:

- Lint-free cleaning wipes
- A plastic bottle for isopropyl alcohol
- A cleaning tray for cleaning paper-pick rollers
- Cleaning instructions (you may use those instructions, or follow the instructions in the next few pages)

For the cleaning kit that is shipped with the printer, you must supply isopropyl alcohol (available at pharmacies); shipping regulations prohibit supplying alcohol or presoaked cleaning materials with the printer.

In general, you should use the purest isopropyl alcohol available to you. 99% pure is best, and 90% also works well.

Caution *Do not use rubbing alcohol because it can contain oils that leave undesirable residue on the printer parts.*

Note *To order a new cleaning kit, call your dealer or Tektronix (order number 016-1233-00). You can also order a cleaning kit containing presoaked alcohol cleaning wipes (order number 016-1276-00).*

Cleaning the printer (with every transfer roll change)

Perform the next three cleaning procedures every time you replace the transfer roll.

Note *Turn off the printer before cleaning the thermal head and the paper-feed rollers. The printer must be turned on to clean the paper-pick rollers.*

Cleaning the thermal head and transfer roll guide

1. Press the button to open the top cover. Dampen a lint-free cleaning wipe with isopropyl alcohol.
2. Wipe the full width of the thermal head several times. Remove any dust, dirt, and wax.
3. Wipe the full width of the transfer roll guide several times. Close the top cover when you are finished .

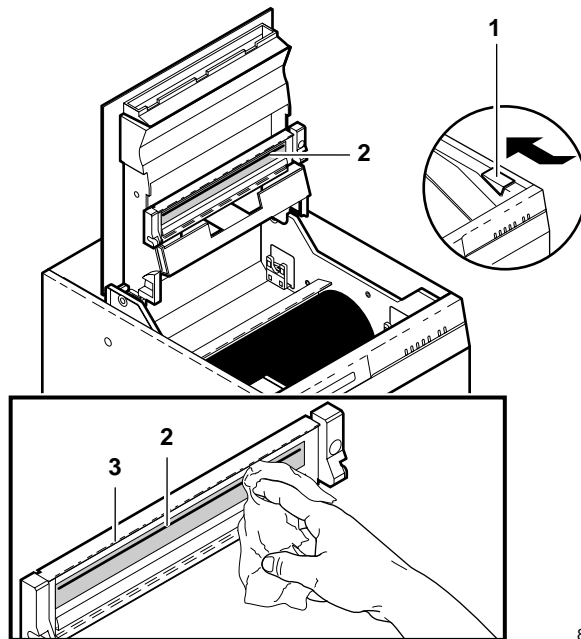

8869-30

Cleaning the paper-feed rollers

Caution *Be careful not to scratch the curved plastic parts inside the front cover. Scratches in this area could cause paper jams.*

1. Slide out the front cover and remove it. Dampen a lint-free cleaning wipe with isopropyl alcohol.
2. Wipe the paper-feed rollers. Be sure to clean all three rollers. It is not necessary to move the rollers as you clean them; clean only the exposed surface of the rollers.
3. Slide the front cover back into place.

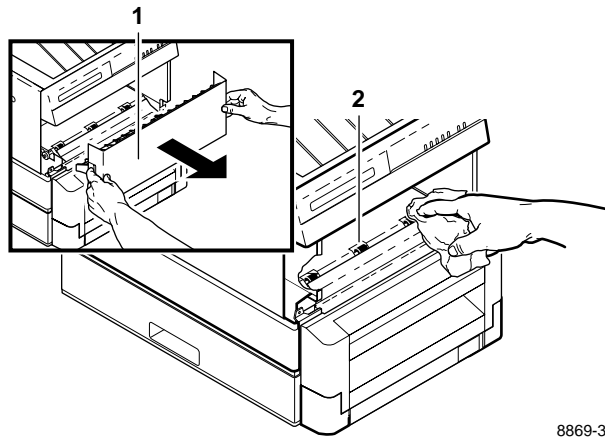

8869-31

Cleaning the paper-pick rollers

Make sure that the transfer roll is installed before you begin this cleaning procedure.

To clean the paper-pick rollers, you must use the cleaning tray from the cleaning kit.

1. Turn the printer off, then on again.
2. Remove the paper tray(s), and remove the paper or transparencies from one of the trays.

When removing paper or transparencies, do not push the paper tray's metal plate down. (If the metal plate is down, put the paper tray into the slot and pull it out; this returns the metal plate to the up position.)

3. If you are using an A4-size (metric) paper tray, break off the tabs on the sides of the cleaning tray. The allows the cleaning tray to fit into the metric paper tray. **Do not break off the tabs if you are using an A-size (U.S.) paper tray.**

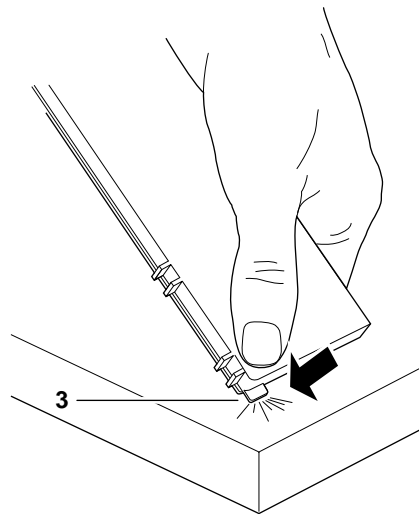

8869-32

4. Open the cleaning tray.
5. Dampen the pad on the cleaning tray with isopropyl alcohol. Dampen the entire surface of the pad.
6. Slide the cleaning tray into the paper tray. As you slide the cleaning tray into position, press down the paper tray's metal plate slightly. When the cleaning tray is properly installed, the paper tray's metal plate presses up against the cleaning tray, holding it in place.
7. Make sure that the flanges on the front of the cleaning tray overlap the front of the metal plate.

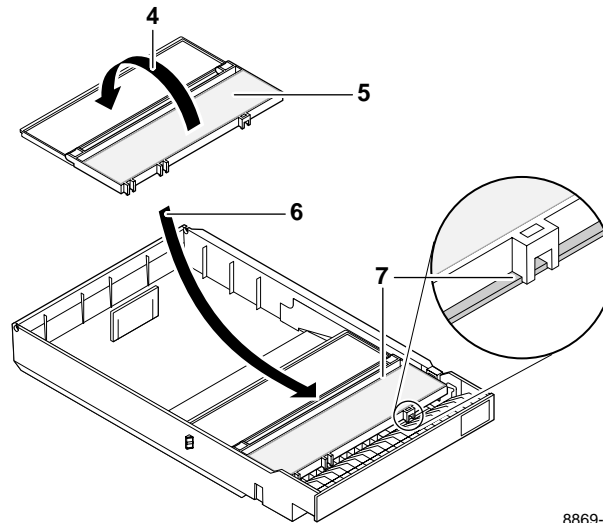

8869-15

8. Slide the paper tray (containing the cleaning tray) into the slot. If your printer has a lower tray assembly, slide the tray into the **lower** slot.
9. Press the **TEST** button on the back of the printer for 3 seconds. The printer attempts to load paper, bringing the paper-pick rollers in contact with the alcohol-dampened pad in the cleaning tray.
10. The **JAM** indicator blinks, indicating that the rollers have been cleaned.
 - a. If your printer has a single paper tray, the procedure is complete. Slide out the paper tray, remove the cleaning tray, and replace the paper or transparencies. Slide the paper tray back into the slot. If paper-picking problems occur, repeat this cleaning procedure.
 - b. If your printer has a lower tray assembly, pull out the paper tray a few inches and then push it back in to clear the **JAM** indicator. Then perform the steps on the next page to complete the procedure.

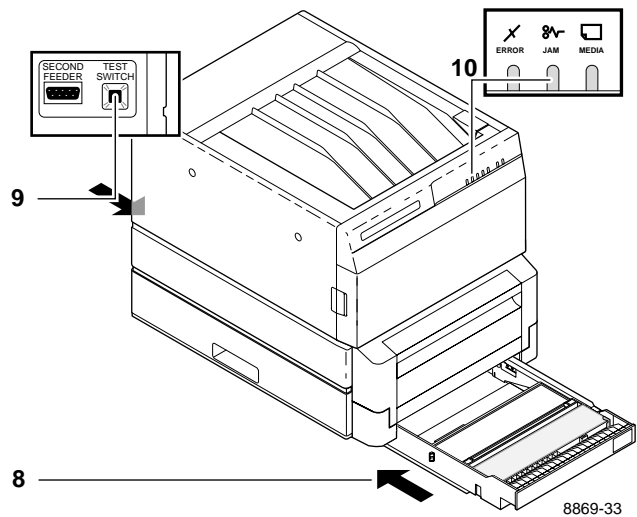

To complete the paper-pick roller cleaning for printers with a lower tray assembly:

1. Remove the paper tray (containing the cleaning tray) from the lower slot. Dampen the pad on the cleaning tray again.
2. Insert the paper tray (containing the cleaning tray) into the upper slot. (Leave the lower slot empty for now.)
3. Press the **TEST** button on the back of the printer for 3 seconds. Again, the printer attempts to load paper, bringing the paper-pick rollers in contact with the alcohol-dampened pad in the cleaning tray.
4. The **JAM** indicator blinks, indicating that the rollers have been cleaned.
5. Pull out the paper tray. Remove the cleaning tray from the paper tray, and replace the paper or transparencies. Put both paper trays back into their slots.

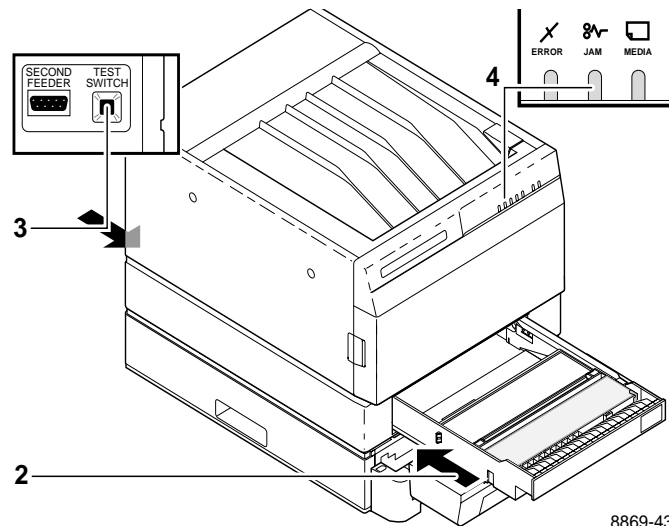

8869-43

Cleaning the printer (every 5000 prints)

Perform the next three procedures every 5000 prints.

Note *Turn off the printer before performing these three cleaning procedures.*

Cleaning the transfer roll sensor pad

1. Press the button to open the top cover.
2. Remove the transfer roll.

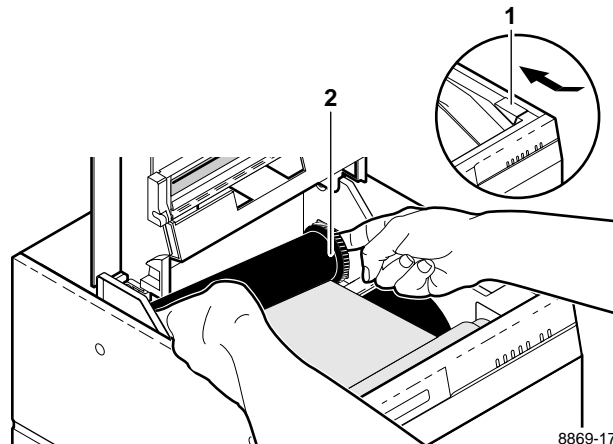

8869-17

3. Dampen a lint-free cleaning wipe with isopropyl alcohol. Wipe the transfer roll sensor.
4. Leave the transfer roll out and the top cover open. Go on to the next procedure.

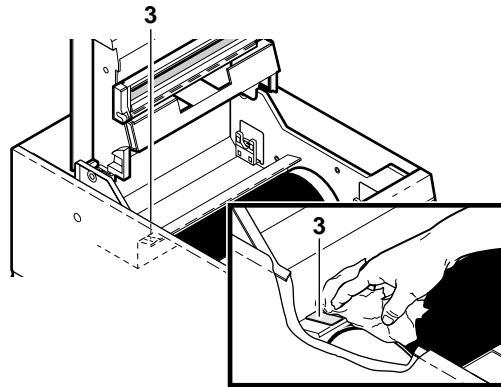

8869-34

Cleaning the drum

1. To clean the drum, you must have the top cover open and the transfer roll removed.
2. Dampen a lint-free cleaning wipe with isopropyl alcohol. Wipe the drum. Move the drum toward the front of the printer to access the entire surface of the drum as you clean.
3. When the alcohol on the drum is dry, put the transfer roll back into the printer and close the top cover.

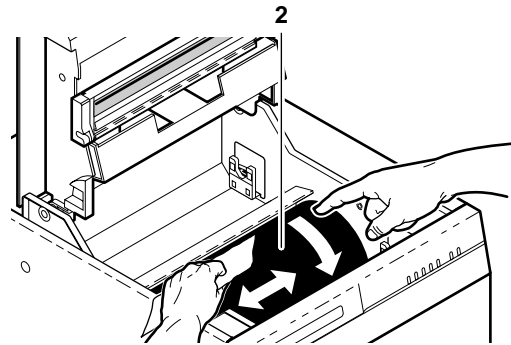

8869-35

Cleaning the exit rollers

1. Slide out the front cover and remove it.
2. Dampen a lint-free cleaning wipe with isopropyl alcohol. Wipe the exit-feed rollers. Be sure to clean all three rollers. It is not necessary to move the rollers as you clean; clean only the exposed surface of the rollers.
3. Replace the front cover.

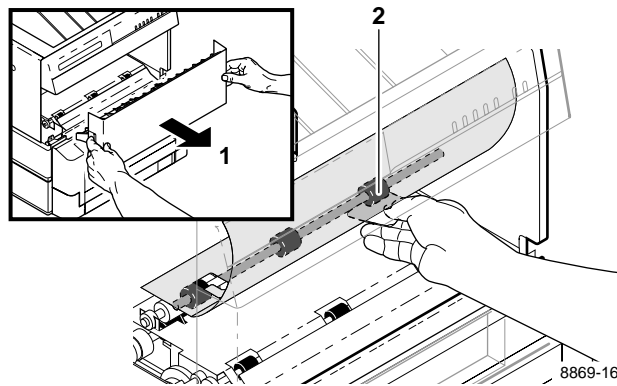

4 *Caring for Your Printer*

Supplies

Always use Tektronix supplies

Tektronix supplies for the Phaser 220 printer are developed and tested as a total *system*: printer, transfer rolls, and media. These components work together to produce consistent, high-quality color images.

Use *only* Tektronix transparencies and transfer rolls. When printing with a 3-color or black transfer roll, use *only* Tektronix thermal-transfer paper. When printing with a ColorCoat transfer roll on common laser paper, use paper that conforms to the guidelines given in Refer to the topic “Recommended paper types” on page 5-4.

Ordering information

To order supplies or upgrade kits, refer to the supplies information sheet that came with the printer and contact your local dealer or, in the U.S.A., call Tektronix at **1-800-835-6100**.

Supplies kits

4681FSS	Plain-paper startup kit including ColorCoat™ transfer roll, paper tray for non-perforated plain paper, and perforated premium laser paper. Order Option 01 to get a metric paper tray and metric paper.
4681FTA	Lower tray assembly (including paper tray for perforated paper). Order Option 01 to get a metric paper tray.

Using plain paper

Note *When printing on plain paper, the sound of the printer is louder than for thermal-transfer paper. This is normal.*

The Phaser 220 printers give prints on standard laser paper the brilliant color quality previously available only with coated thermal-transfer papers. The excellent plain-paper printing capability of the Phaser 220 printers is possible through Tektronix' proprietary ColorCoat™ technology. This topic provides details on the Phaser 220 plain-paper printing capabilities.

ColorCoat™ transfer roll

Plain-paper printing requires a special ColorCoat™ transfer roll. The ColorCoat™ transfer roll uses a fourth panel to put a specially formulated *precoat* on the paper, allowing it to accept the thermal-wax inks and retain their vivid colors. The printer's image processing software determines where the precoat is needed and avoids placing the precoat where there is no color (for example, white areas).

The ColorCoat™ transfer roll also prints well on coated thermal-transfer paper and on transparencies. (When the selection switch on the paper tray is set to TRANSPARENCY, the precoat is not applied.) The standard thermal-wax transfer roll does not print well on plain paper.

Use the correct paper tray for plain-paper printing

If you use common laser paper for plain-paper printing, you must use a LETTER or A4 size paper tray. The standard trays supplied with the printer are for Tektronix perforated paper and transparencies (they are labeled LETTER PERF and A4 PERF). LETTER and A4 trays for plain paper must be ordered separately. If you use Letter or A4 size plain paper in a LETTER PERF or A4 PERF paper tray, the printer reports an error condition.

Paper trays and media types

Tray	Media
LETTER A4	Common laser paper
LETTER PERF A-4 PERF	Tektronix premium laser paper (perforated) Tektronix thermal-transfer paper (perforated) Tektronix transparencies (perforated)

Plain-paper startup kit

For first-time startup using plain-paper printing capability, order the plain-paper startup kit (4681FSS), which contains everything you need for plain-paper printing.

Recommended paper types

Observe the following guidelines when selecting plain paper for use with the printer:

- Many types of Bond, Text, and Book paper work well with the printer. For Bond paper, use a basis weight of 75 - 90 g/m² (20 - 24 lb.); 75 g/m² (20 lb.) is best. For Book paper, 75 g/m² (50 lb.) is best. In general, avoid paper with a high rag content.
- In general, smoother papers work better. Avoid using “fuzzy” papers with loose fibers. This type of paper does not produce the best image quality and leaves more paper residue inside the printer, requiring you to clean the printer more frequently.
- Don't use watermarked paper. The watermark may show through as dropout on the print.
- You can recycle plain-paper prints with other mixed paper.

Tektronix offers a premium laser paper that gives excellent print quality for plain-paper printing. Like Tektronix thermal-transfer paper, this premium laser paper is larger than standard Letter or A4 size paper and perforated, which allows you to print the largest possible image area (for details, see “Margins and print area” on page 3-6). For information on ordering Tektronix premium laser paper and other printer supplies, refer to the supplies information sheet that is shipped with the printer.

The following table lists a selection of papers that provide good results. Some office papers, especially in Europe, may be too rough to provide good print quality. For best results on plain paper, use Tektronix perforated premium laser paper.

Recommended paper types

Paper	Basis weight
Aussedat Rey Rdeerey (France)	100g/m ²
Boise Cascade Laser	20 lb.
Boise Cascade Laser	24 lb.
Boise Cascade Xerographic	20 lb.
Champion Bond	20 lb.
Cross Point Laser/Recycled	24 lb.
Hammermill Laser Print	24 lb.
Nashua Dual Purpose	20 lb.
Nekoosa Laser 1000	24 lb.
Neusiedler Color Copy (Austria)	100g/m ²
Nymoella MultiCopy Art (Sweden)	100 g/m ²
Western Red Label (HM)	20 lb.
Xerox 4024 Smooth	20 lb.
Zellerbach Matrix Plus	20 lb.

Handling supplies

- Make sure that the paper trays are free of dust. Dust and dirt in a paper tray can be transferred to the paper, resulting in poor print quality.
- Handle paper and transparencies at the edges to avoid fingerprints.
- Store paper and transparencies in the original, dust-free package.
- Handle transparencies with both hands to avoid creases, which can result in poor print quality.
- To avoid having transparencies or perforated paper stick together, fan them before loading into the paper tray.
- If you switch transfer rolls temporarily, be sure to store the partially used transfer roll so that it will not be exposed to dust or dirt. The best way to store a partially used transfer roll is to put it back into its original packing material and plastic bag.

Removing a used transfer roll

Note *Negative images of all prints remain on the used transfer roll. If this is a security risk, dispose of the used transfer roll properly.*

Every time you replace a transfer roll, you must clean three printer components. This cleaning is user care that helps ensure reliable operation and uniformly high print quality. Cleaning instructions are provided with each transfer roll. You may also refer to Chapter 4, or refer to the *Phaser 220 Color Printers Cleaning Instructions* that come with each cleaning kit.

1. Push the button and open the printer's top cover.
2. Lift out the back spool of the used transfer roll.
3. Lift out the front spool of the used transfer roll.
4. To install the new transfer roll, follow the instructions on the sheet that comes with each transfer roll, or refer to “Install the transfer roll” on page 2-7.

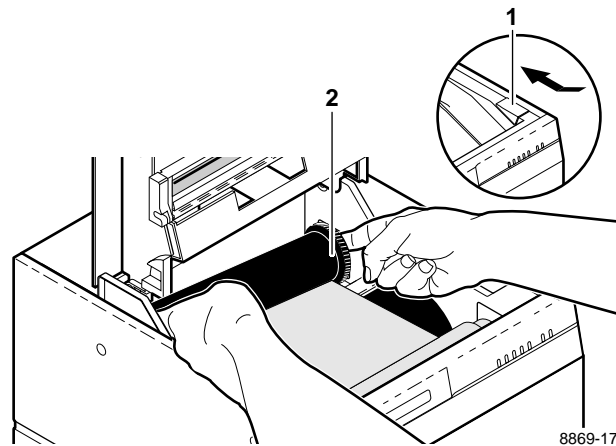

Troubleshooting

Clearing transfer roll jams

1. Push the button and open the printer's top cover.
2. Lift out the transfer roll. Check the roll for tears and wrinkles. (If the roll is damaged, replace it with a new one.) Straighten the roll and put it back in. Make sure the transfer roll is properly installed: the black band is on the left, with the unused end in the back of the printer.

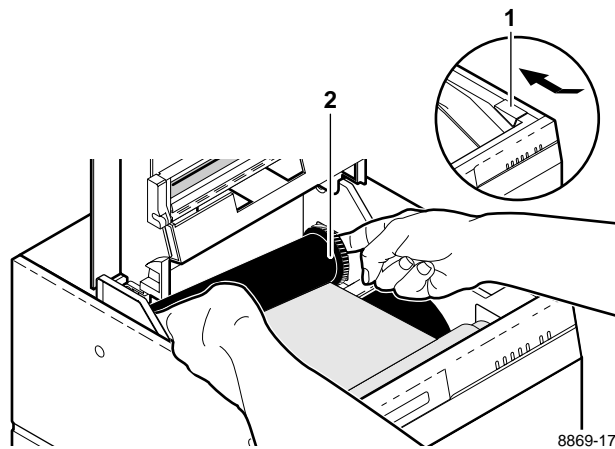

8869-17

Clearing paper jams

If a paper jam occurs, the JAM indicator comes on. Follow these steps to remove the jam:

1. Remove the paper tray(s).
2. Carefully remove any jammed paper from the paper tray slot(s) and replace the tray(s).

Caution *Be careful not to scratch the curved plastic parts inside the front cover. Scratches in this area could cause paper jams.*

3. Slide out the front cover and remove it.
4. Remove any jammed paper from inside the printer and replace the front cover. If you did not find paper jammed in the paper tray slot(s) or inside the printer, it is wrapped around the drum, and you must go to the next procedure .

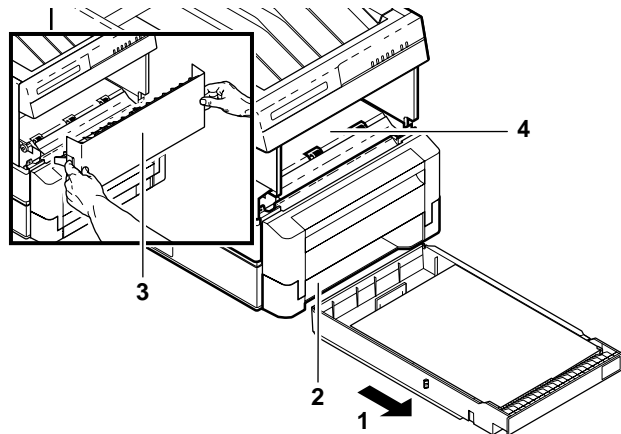

8869-36

To remove paper from the drum:

1. Push the button and open the printer's top cover.
2. Remove the transfer roll.

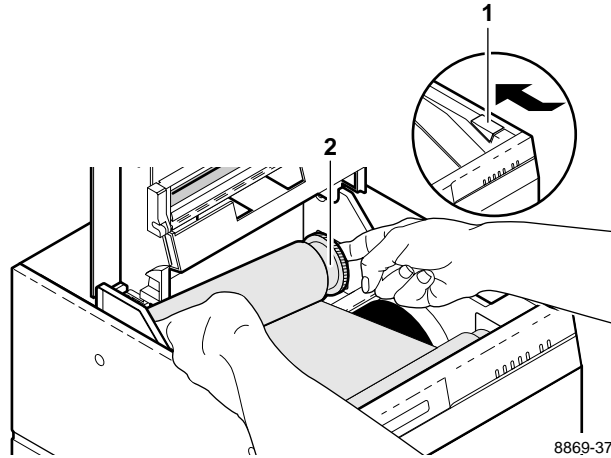

Caution *Be careful not to scratch the drum. Scratches can affect print quality.*

Note *If you getting frequent jams when using thermal-transfer paper or transparencies, make sure you are using Tektronix media (order from the supplies information sheet that is shipped with your printer).*

3. Turn drum toward the front of the printer until the edge of the paper is visible.

Note *If you have not yet found any paper jammed in the printer, the printer has failed to pick up the paper (reported as a paper jam). cleaning the paper-pick rollers should fix the problem. See “Cleaning the paper-pick rollers” on page 4-6.*

4. The paper is clamped to the drum. If you pull the paper out without releasing the clamp, you may tear the paper and leave some pieces inside the printer.

To open the clamp, move the drum toward the back of the printer until it stops. Then gently continue the motion until you hear a click; now the clamp is open and you can remove the paper without tearing it.

5. Replace the transfer roll and close the top cover.

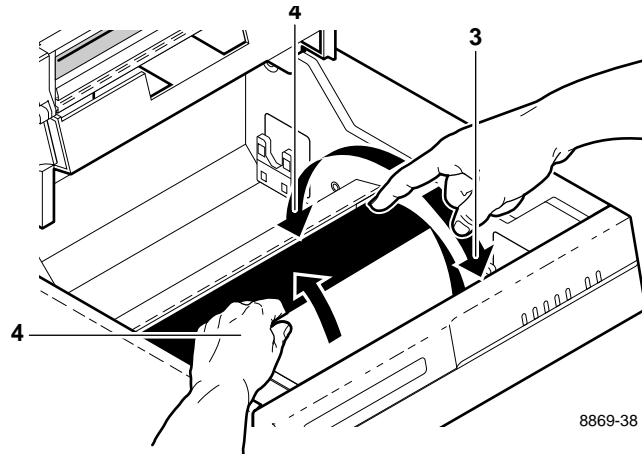

Problems and solutions

If you can't make a print

Note *When using a printer with a lower tray assembly, make sure that the door covering the upper slot is closed before you try to make a print from the lower tray. You cannot print from the lower tray with the door open.*

Printer not operating

Make sure you plugged in the printer and turned it on. Make sure you connected the interface cable properly and set the rear panel switches correctly. For details on the switch settings, refer to Chapter 7. Make sure the line voltage selector switch is set properly.

Press the **TEST** button on the back of the printer for 3 seconds. If the printer produces a test print, the printer is functional, and the next step is to verify that your computer can communicate with the printer. If the printer fails to produce a test print, make sure that paper is loaded and a transfer roll is installed. If you have paper and transfer roll installed and the printer does not produce a test print, the printer requires service.

Note *When you have checked all possible causes and your printer is still not operating, you can call for service at 1-800-547-8949 in the U.S.A. and Canada, or call your Tektronix dealer.*

To verify that your computer can communicate with the printer, use one of these methods:

- If you have a Macintosh, make sure you have the correct driver installed and that you have selected the printer in the **Chooser**. If the printer's name does not appear in the Chooser, your LocalTalk or EtherTalk connection may be faulty. (See also “Printer doesn't appear in the Chooser” on page 6-7.

You can use the **Print Directory** command to send a file to the printer without using an application. If the communication link between your computer and the printer is working, the printer produces a directory listing of the active window on the desktop.

- If you have a PC, use this DOS **ECHO** command:

```
ECHO %! > port
```

```
ECHO SHOWPAGE[CTRL-D] > port
```

Where [CTRL-D] indicates pressing the **D** key while holding down the **CTRL** key. Substitute the name of the printer port (for example **COM1:**, **COM2:**, **LPT1:**, **LPT2:**) for the variable *port* in this command. For example, if you are testing a parallel connection on **LPT1**, type:

```
ECHO %! > LPT1:
```

```
ECHO SHOWPAGE[CTRL-D] > LPT1:
```

If the communication link between your computer and the printer is working, the printer ejects a blank page. If this works, but you cannot print from your application or through Windows, make sure that the appropriate driver is installed and that you have selected the printer correctly.

Printer doesn't appear in the Chooser

Make sure the printer is turned on and the cables are correctly attached. Check the termination (refer to the documentation for your Ethernet adapter or LocalTalk connector for information on termination).

Make sure you have the correct zone selected in the **Chooser** before looking for the printer's name in the list of printers. If you have changed the printer's name, make sure you have given it a unique name (not the same as any other printer in the zone).

READY light blinks, but the file does not print

This is probably the result of a PostScript error. Download the PostScript error handler file from the Phaser 220 utility diskettes. For more information on using the PostScript error handler, see the manual *Phaser 220 Drivers and Utilities Printing Reference*.

MEDIA light blinks, and no print is produced

You have the wrong size paper in the paper tray (non-perforated paper in a tray for perforated paper).

Print job does not finish (the printer times out)

If you are using the serial or parallel port from a PC, make sure that you used the **MODE** command to set the PC's communication parameters. For example:

```
MODE LPT1:.,P > NUL
```

```
MODE COM1:9600,N,8,1,P
```

The **P** parameter in these commands sets the port timeout to **Infinite Retry** and must be part of the command.

If you are using Windows 3.1, make sure the Transmission Retry value for the printer's assigned port is set to **995**. For more information, see "PC users" on page 2-23.

Media problems

Frequent paper-picking errors

Be sure to fan the paper or transparencies before installing them in the paper tray. This is especially important for transparencies and perforated paper. If you still experience paper-picking errors, clean the paper-pick rollers. For details, see “Cleaning the paper-pick rollers” on page 4-6.

Frequent paper jams

If you are using thermal-transfer paper or transparencies, make sure that you use the Tektronix paper and transparency film listed in the supplies information sheet. Also, do not overfill the paper tray, as indicated by the red line on the right side of the tray. If you still experience paper jams, clean the printer. For information on cleaning the printer, see Chapter 4.

You feel resistance when installing the paper tray

If you try to install a paper tray and you find it won't go in, look in the slot. If you see the paper-pick rollers in the way, rotate the rollers toward the front of the printer until the slot is clear.

Problems with image size and position

Off-set images

Check your application for correct image sizing.

Cut-off images

Check your application for image sizing.

If you are using non-perforated plain paper, make sure you are using a Phaser 220 driver and have selected **Letter** or **A4** as the paper size. If you select **Letter Perf** or **A4 Perf** and print on non-perforated paper, the image may be cut off.

Image prints over perforations

Reverse the direction of the paper or transparencies in the tray. The perforated portion of the paper or transparencies must be in the front of the tray. (The front of the tray is the part that has the paper-size label: LETTER, LETTER PERF, A4, A4-PERF.)

Margins are too big with perforated paper or transparencies

Make sure you are using a Phaser 220 driver and have selected Letter Perforated or A4 Perforated as the paper size.

Image shifts or margins are incorrect (Macintosh)

For details on how to print from a Macintosh, refer to “Printing from a Macintosh” on page 3-1. You should install the Phaser 220i or Phaser 220e printer driver onto your Macintosh so you can select the correct page sizes from the driver. For details on the Phaser 220i and Phaser 220e drivers, refer to the manual *Phaser 220 Drivers and Utilities Printing Reference*.

Print quality problems

Plain paper prints have dull, faded colors and significant dropout

If plain paper prints have dull, faded colors and significant dropout (areas where the wax does not adhere to the paper), make sure that you are using a ColorCoat™ transfer roll; the thermal-wax transfer roll does not print well on plain paper. If a transfer roll has a clear panel after every three colored panels, it is a ColorCoat™ transfer roll.

If you are using Tektronix perforated premium laser paper, make sure you have the selection switch on the paper tray set to PAPER and not TRANSPARENCY.

If you have the correct transfer roll and switch selection and the prints still have dull, faded colors and dropout, you may be using a paper that is too rough. Try another type of plain paper. Refer to “Recommended paper types” on page 5-4. You can achieve excellent results with Tektronix perforated premium laser paper.

Prints on thermal-transfer paper or transparencies have dull colors

Make sure the switch on the paper tray is set to PAPER, not TRANSPARENCY. If you are using thermal-transfer paper, make sure that you load the paper in the tray with the whiter, shinier side up.

Streaks or spots

Most spots and streaks are caused by dust introduced into the printer during transfer roll installation or paper loading. To prevent dust from getting inside of the printer, make sure the surface where you unpack transfer rolls, paper, and transparencies is free of dust. Keep supplies in a covered area or a closed box.

To get rid of spots or streaks, clean the thermal head (see “Cleaning the thermal head and transfer roll guide” on page 4-4).

Black-and-white instead of color

- Make sure that a color transfer roll is installed in the printer.
- If you have a Macintosh, make sure you are using the Phaser 220i or Phaser 220e driver or the latest Apple LaserWriter printer driver (version 6.0.7 or higher), which supports color PostScript. Make sure **Color/Grayscale** is selected in the **Print** dialog box. Some applications require special files to print in color. Make sure that these files are properly installed. For information, refer to the manual *Phaser 220 Drivers and Utilities Printing Reference*.
- If you have a PC, be sure to use a driver that supports color PostScript. If you are using Windows 3.1, use the Phaser 220i or Phaser 220e driver. If you are using Windows, make sure that the **Color** box in the **Options** dialog box is checked. For information on the drivers, refer to the manual *Phaser 220 Drivers and Utilities Printing Reference*.

Startup page prints even though it is disabled

The printer's power-up self-test can detect problems that do not necessarily make the printer completely inoperable. Examples of these *non-fatal* errors include faulty printer ports and some memory failures.

If the printer detects a non-fatal error at power-up, the startup page prints, even if you have disabled it. In this case, the page contains one or more of the error messages listed in the following table. Depending on your needs, you may not need to call for service immediately.

Error messages on the startup page

Message	Description
Serial Port failed	The named port is not working. The other ports can still be used.
Parallel Port failed	
LocalTalk Port failed	
Ethernet Port failed (Phaser 220i only)	
SCSI Port failed (Phaser 220i only)	
Font SIMM failed (Phaser 220e only)	The optional FONT SIMM is not working. The printer can still be used, but only the standard 17 fonts are available.
DRAM SIMM failed (Phaser 220e only)	The memory SIMM is not working. Since the printer's base memory is still working, the printer can still be used, but large image files may not print, and throughput may suffer.
DRAM SIMM x failed (Phaser 220i only)	One of the memory SIMMs is not working. In this message, x indicates the number of the SIMM that failed. Since the printer's base memory is still working, the printer can still be used, but large image files may not print, and throughput may suffer.

Generating the configuration page

The Phaser 220 can generate a configuration page that contains useful information for installation and troubleshooting.

There are two ways to generate the configuration page:

- **Use the printer's rear panel DIP switches.**
 1. Set Switches 2, 3, and 4 *down*.
 2. After about five seconds, set Switch 4 *up* (leave Switches 2 and 3 *down*). The printer generates the configuration page as soon as the switches are set (you do not have to reset the printer).
- **Send a PostScript language file to the printer.** For information on how to generate the configuration page by sending a PostScript language file to the printer, see the manual *Phaser 220 Drivers and Utilities Printing Reference*.

Whom to call for help

Call your dealer or a Tektronix sales representative for assistance, or in the U.S.A. and Canada, call the Customer Support Hot Line at Tektronix at **1-800-835-6100**. The Customer Support Hot Line is staffed from 6:00 am to 5:00 pm Pacific Time. To avoid peak hours, call before 11:00 am or after 2:00 pm Pacific Time.

For technical support outside the United States and Canada, contact your local Tektronix dealer or Tektronix sales representative.

If your printer needs repair, call **1-800-547-8949** (in the U.S.A., from 5:00 am to 5:00 pm PST).

HAL — Highly Automated Library

As an alternative to the Customer Support Hotline, and to provide up-to-date information quickly, Tektronix has set up HAL, an interactive, automated fax system. Topics include:

- The latest technical hints and tips
- Solutions to most common technical problems
- Application notes (for example, QuarkXPress and CorelDRAW!)
- Data sheets
- Sales literature

To order a technical support catalog listing all available HAL articles, call **(503) 682-7450** directly from any phone (24 hours/day, from anywhere in the world). In the United States and Canada, call toll-free **1-800-835-6100** (6:00 am — 5:00 pm, PST) and ask to be transferred to HAL. To order a HAL catalog or document, do the following:

1. Before you call, write down the area code and phone number for your fax machine. HAL will ask you to key this number through the keypad on your voice phone. If you are calling from outside the United States or Canada, you'll need to know the international access code to reach your country from the United States. Without a complete fax number, HAL cannot call your fax machine. Call only from a touch-tone voice phone.

Note *Before ordering documents from HAL, order a HAL catalog listing the numbers of the available documents.*

2. Follow the instructions in the voice-prompted menu.
3. Order individual documents by entering the desired document's number as listed in the HAL catalog. Enter the number by using the telephone's keypad.
4. You can order up to 3 documents per call.
5. The HAL catalog or documents you request are faxed to you in a matter of minutes.

Front and Rear Panels

Rear panel (Phaser 220e)

1. Status indicator
2. DIP switches
3. LocalTalk connector
4. Serial connector
5. Parallel connector

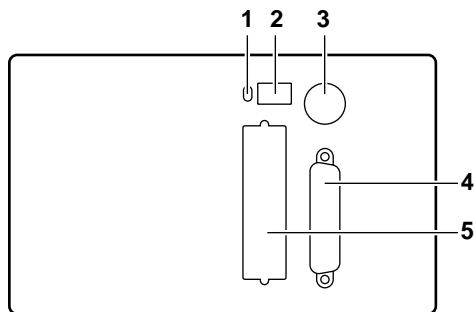

Phaser 220e

8869-10

Rear panel DIP switches (Phaser 220e)

Phaser 220e rear panel DIP switches

Switch	Function	Settings
1	Reset/run	<p><i>Up:</i> The printer resets and does not accept data while the switch is in this position.</p> <p><i>Down:</i> The printer runs a self-test, then proceeds to run normally. Leave the switch <i>down</i> for normal operation.</p>
2, 3, and 4	Serial port Color correction Configuration page	See the next table, "Phaser 220e DIP Switches 2, 3, and 4."

In this table, *D* indicates that the switch is *down*; *U* indicates that the switch is *up*.

Phaser 220e DIP Switches 2, 3, and 4

Switches			Operation	Features	
2	3	4		Serial port	Color correction
<i>D</i>	<i>D</i>	<i>D</i>	Normal	Variable	None
<i>U</i>	<i>D</i>	<i>D</i>	Fixed serial parameters	Fixed	None
<i>D</i>	<i>U</i>	<i>D</i>	Color correction	Variable	Vivid blue
<i>U</i>	<i>U</i>	<i>D</i>	For service personnel only	Variable	None
<i>D</i>	<i>D</i>	<i>U</i>	Print configuration page*	Variable	None
<i>U</i>	<i>D</i>	<i>U</i>	Enable sample prints	Variable	None
<i>D</i>	<i>U</i>	<i>U</i>	For service personnel only	Variable	None
<i>U</i>	<i>U</i>	<i>U</i>	For service personnel only	Variable	None

*To print the configuration page, first set Switches 2, 3, and 4 *down*. After about 5 seconds, set Switch 4 *up*.

Note *If your printer is on a network and you have changed rear panel Switches 2, 3, and 4 for color correction, make sure you tell other users on the network, since the color correction affects **all** prints made with non-Tektronix drivers or the **Use Printer Setting** option in the Tektronix drivers. Color correction selections made in the Phaser 220 driver take priority over selections made by setting the printer's rear-panel DIP switches.*

Rear panel (Phaser 220i)

1. Status indicator
2. DIP switches
3. LocalTalk connector
4. Ethernet connector
5. SCSI connector (for adding a hard disk for font storage)
6. Parallel connector
7. Serial connector

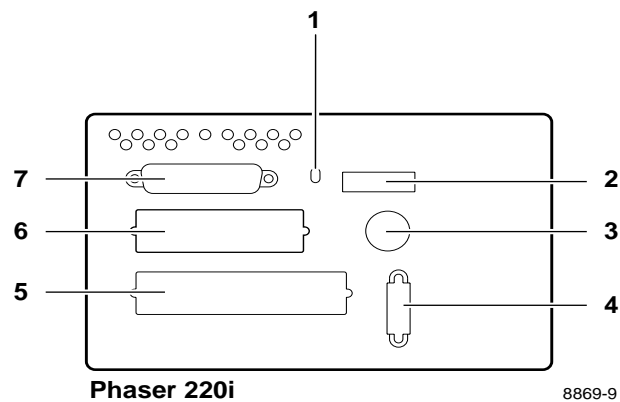

Rear panel DIP switches (Phaser 220i)

Phaser 220i rear panel DIP switches

Switch	Function	Settings
1	Reset/run	<p><i>Up:</i> The printer resets and does not accept data while the switch is in this position.</p> <p><i>Down:</i> The printer runs a self-test, then proceeds to run normally. Leave the switch <i>down</i> for normal operation.</p>
2, 3, and 4	Configuration page Sample prints	See the table, "Phaser 220i DIP Switches 2, 3, and 4" on page 7-5.
5	Start Job	<p><i>Up:</i> The Sys/Start job on the hard disk does not run.</p> <p><i>Down:</i> The Sys/Start job runs.</p>
6	Unused	
7	Baud Rate	<p><i>Up:</i> Fixed. Sets the serial communication parameters to 1200 baud, software flagging, and ignore parity.</p> <p><i>Down:</i> Variable. Lets you change the serial communication parameters. The factory setting is 9600 baud, software flagging, and ignore parity.</p>
8 and 9	Color correction	See the table, "Phaser 220i DIP Switches 8 and 9" on page 7-5.

Phaser 220i DIP Switches 2, 3, and 4

Switch 2	Switch 3	Switch 4	Function
<i>Down</i>	<i>Down</i>	<i>Down</i>	Default, normal operation
<i>Up</i>	<i>Down</i>	<i>Down</i>	For qualified service personnel
<i>Down</i>	<i>Up</i>	<i>Down</i>	For qualified service personnel
<i>Up</i>	<i>Up</i>	<i>Down</i>	For qualified service personnel
<i>Down</i>	<i>Down</i>	<i>Up</i>	Prints configuration page*
<i>Up</i>	<i>Down</i>	<i>Up</i>	Enables printing of sample prints at power-up
<i>Down</i>	<i>Up</i>	<i>Up</i>	Not used
<i>Up</i>	<i>Up</i>	<i>Up</i>	Not used

*To print the configuration page, first set Switches 2, 3, and 4 *down*. After about 5 seconds, set Switch 4 *up*.

Phaser 220i DIP Switches 8 and 9

Switch 8	Switch 9	Function
<i>Down</i>	<i>Down</i>	No color correction (factory default).
<i>Down</i>	<i>Up</i>	SWOP Press.
<i>Up</i>	<i>Down</i>	Vivid Blue.
<i>Up</i>	<i>Up</i>	Variable. Vivid blue is the default, but you can change this setting by using files on the Phaser 220 drivers and utilities diskettes.

Note *If your printer is on a network and you have changed rear panel Switches 8 or 9, make sure you tell other users on the network, since the switches affect **all** prints made with non-Tektronix drivers or the **Use Printer Setting** option in the Tektronix drivers. Color correction selections made in the Phaser 220 driver take priority over selections made by setting the printer's rear-panel DIP switches.*

Front panel (Phaser 220i and Phaser 220e)

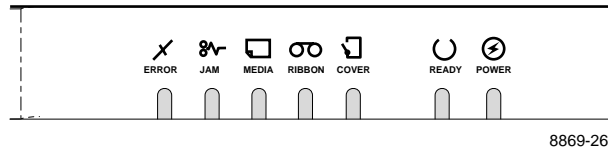

Indicator	On	Blinking	Off
POWER	The POWER switch is on.	Not applicable.	The POWER switch is off, the printer is unplugged, or the power supply has failed.
READY	The printer is ready for operation.	The printer is processing or printing an image.	The printer is not ready, or there is an error.
ERROR	The print engine has an error that is not user-correctable. If this indicator lights at any time other than power-up, turn the printer off, wait 30 seconds, then turn it on again. If the indicator lights again, the printer requires service.	The printer's controller board has an error that is not user-correctable. If this indicator lights at any time other than power-up, turn the printer off, wait 30 seconds, then turn it on again. If the indicator lights again, the printer requires service.	Normal operation: there are no print engine or controller board errors.
JAM	Media is jammed inside the printer.	The printer has failed to pick up the media for a print job. Remove the paper tray and put it back in to clear the error. It may be necessary to clean the paper pick rollers. See "Cleaning the paper-pick rollers" on page 4-6.	Normal operation: there are no media jams.
MEDIA	There is no media in the selected tray, or the selected tray is not installed.	The media in the selected tray is the wrong size for that tray.	Media is ready to feed.
COVER	The top cover or the front cover is open. The printer does not print while covers are open.	Not applicable.	Normal operation: the top cover and front cover are closed.
RIBBON	At least 75% of the transfer roll is used up. The printer can make prints with the remainder of the transfer roll.	Transfer roll is used up or not installed. This light will also blink if a non-Tektronix transfer roll is installed.	Normal operation: less than 75% of the transfer roll is used up. The transfer roll is ready to make prints.

A

Technical Notes

Printer ports

Parallel port

The printer has a standard unidirectional, byte-wide parallel, synchronous port. When you use the parallel port, be sure to type this command at the PC (if **LPT1** is not available, use **LPT2**):

MODE LPT1:.,P

The table on the next page shows the parallel port's connected pins. Other pins are not connected. Signal names ending with a dash (-) are asserted low.

Parallel port signal descriptions

Signal name	Pin #	Return pin	Signal source	Description
DSTRB-	1	19	Host	Pulsed low for .5 microseconds; clocks data into printer
DATA1	2	20	Host	Positive true data input
DATA2	3	21	Host	Positive true data input
DATA3	4	22	Host	Positive true data input
DATA4	5	23	Host	Positive true data input
DATA5	6	24	Host	Positive true data input
DATA6	7	25	Host	Positive true data input
DATA7	8	26	Host	Positive true data input
DATA8	9	27	Host	Positive true data input
ACK-	10	28	Printer	Data acknowledge pulsed low for 3-4 microseconds; ends bus transaction
BUSY	11	29	Printer	Positive true = cannot accept data
PE	12	-	Printer	Positive true = out of paper or transfer roll
SLCT	13	-	Printer	Positive true = printer selected
INPRIME-	31	30	Host	Negative true = printer port reset
FAULT-	32	-	Printer	Negative true = printer fault indicator
Frame Gnd	-	17	Printer	Frame ground
SGnd	-	14,16,33	Printer	Signal ground

Serial port

Phaser 220i and Phaser 220e serial ports provide an RS-232 interface connection to PC's and other hosts. The serial port has these built-in default settings.

Default serial port settings

Serial parameter	Variable setting (factory default)	Fixed setting
Baud rate	9600	1200
Flagging	Software (XON/XOFF)	Software (XON/XOFF)
Parity	None	Space
Data bits	8	7
Check parity	False	False
Protocol	Normal	Normal

Some PC's and Unix hosts do not support **Space** parity. Usually they accept parity values of **odd**, **even**, or **none**. Therefore the closest setting is 1200 baud, 1 stop bit, 8 data bits and no parity, which has the following associated **MODE** statement:

```
MODE COM1:1200,N,8,1,P
```

The **Space** parity forces the parity bit to 0. For most users, 8 data bits and no parity is identical to 7 data bits and **Space** parity.

When the serial port is set for variable baud rate, you can change the serial port's settings. To change the settings, you can send a PostScript language file to the printer. For details, see the manual *Phaser 220 Drivers and Utilities Printing Reference*.

Serial port signals

The table shows the Phaser 220i and Phaser 220e serial port's connected pins. The other pins are not connected.

Serial port signal descriptions

Signal name	Pin number	Printer I/O	Description
SGnd	1	-	Shield ground
TxData	2	Out	Transmitted data
RxData	3	In	Received data
RTS	4	Out	Request to end
CTS	5	In	Clear to send
DSR	6	In	Data set ready
Gnd	7	-	Signal ground
DCD	8	In	Data carrier detect
DTR	20	Out	Data terminal ready
RI	22	In	Ring indicator

Specifications

Temperature

Operating: 15° C to 35° C (59° F to 95° F)

Non-operating: 0° C to 40° C (32° F to 104° F)

Storage: (without paper, transparencies, or transfer roll): -20° C to +60° C (-4° F to +140° F)

Humidity

Operating: 20% to 80% Relative Humidity, non-condensing

Non-operating: 10% to 90% Relative Humidity, non-condensing

Altitude

Operating: 0.8942 kg/m. Minimum air density (about 0 to 15,000 feet at 25° F)

Non-operating: 0 to 50,000 ft. pressure alt.

Primary voltage ranges (switch-selectable)

87 - 128 VAC, 115 VAC nominal

174 - 250 VAC, 220 VAC nominal

Frequency range

48 to 66 Hz

Primary fusing

115 VAC, 5 Amps

220 VAC, 5 Amps

(Not user-accessible)

Heat dissipation

800 BTU/hour (235 Watts)

Dimensions without lower tray assembly

Height: 27.9 cm (11.0 ins.)

Depth: 44.4 cm (17.5 ins.)

Width: 34.0 cm (13.4 ins.)

Dimensions with lower tray assembly

Height: 36.8 cm (14.5 ins.)

Depth: 47.6 cm (18.8 ins.)

Width: 34.0 cm (13.4 ins.)

Weight without lower tray assembly

18.1 kg (40 lbs.)

Weight with lower tray assembly

23.6 kg (52 lbs.)

Printing

300 x 300 dots-per-inch (Standard mode)

300 x 300 dots-per-inch (Enhanced mode)

600 x 300 dots-per-inch (High-resolution mode)

Print speed (paper-marking speed)

The speeds listed in the following table represent the printer's paper-marking speed in standard print mode. The paper-marking speed is the time it takes the printer to put the colored wax on the paper, once it has received the processed image. NA indicates a combination of transfer roll and paper that is not recommended.

Media type	With Black transfer roll	With 3-Color transfer roll	With ColorCoat™ transfer roll
Transparency	16 sec.	30 sec.	36 sec.
Tektronix perforated thermal-transfer paper	16 sec.	30 sec.	49 sec.
Tektronix perforated premium laser paper	NA	NA	49 sec.
Non-perforated plain paper	NA	NA	46 sec.

Note *In Enhanced mode, the paper-marking speed is increased by 10 seconds over Standard mode. In High-resolution mode, image processing time is about 30% longer than with Standard mode. Also, the printer's paper-marking speed can be up to twice as long as Standard mode.*

Standard transfer roll capacities

Black transfer roll: 880 prints

3-Color transfer roll: 342 prints

ColorCoat™ transfer roll: 214 prints

Safety and emissions standards

FCC Part 15, Subpart J “Class B” verified.

VDE 0871 Class B, verified.

CISPR 22 Class B, verified

UL 1950, listed.

CSA 220, certified.

EN60950/IEC 950, TUV licensed.

EN55022.

Vfg 243.

B

Expanding Your Printing System

Upgrade kits

4690F4M	4-Mbyte SIMM for adding memory. (See “Advantages of adding memory” on page B-2.)
4681FTA	Lower tray assembly with A-size (U.S.) paper tray. For metric A4-size paper tray, order 4681FTA Option 01.
4681F1F	Font SIMM (Phaser 220e only; adds 22 fonts for a total of 39).
4680FP1	Ethernet hardware upgrade kit; includes EtherTalk and Novell NetWare protocols. (Phaser 220i only).
4680FP2	Add TCP/IP support (requires 4680FP1 or Option P1 already installed).
4511A	TCP/IP Ethernet interface for Phaser 220e.
4681FXi	Upgrade Phaser 220e to Phaser 220i. (Phaser 220e only).
4681FSS	Plain-paper supplies startup kit. Includes: ColorCoat transfer roll, paper tray for non-perforated plain paper, and non-perforated premium laser paper. Order Option 01 to get a metric paper tray.

Advantages of adding memory

The following table summarizes the memory configurations for Phaser 220 printers:

Memory configurations for Phaser 220 printers

Memory	Phaser 220i	Phaser 220e
Standard	10 Mbytes	8 Mbytes (max.)
Add one 4-Mbyte SIMM	14 Mbytes (max.)	NA

The total amount of memory installed in the printer is reported on the startup page and on the configuration page.

In general, more memory improves throughput, provides more storage for downloadable fonts, and allows printing of the most complex images. Additional memory can also reduce offload time by increasing the size of input buffers for the parallel port. Adding a 4-Mbyte SIMM to a Phaser 220i provides the following specific benefits:

- Larger parallel buffer (500 Kbytes)
- Improved imaging performance
- Improved network performance
- PCL5

Note *For the Phaser 220e, PCL5 is available with the standard memory.*

Adding a hard disk for font storage (Phaser 220i only)

With the Phaser 220i, you can connect one or more Small Computer System Interface (SCSI) external hard disks to the printer and use them for additional font storage. Once you download a font to the external disk, the font remains there until you remove it.

Compatible hard disks

The Phaser 220i can use most SCSI hard disks that support the full SCSI command set. Also, most SCSI hard disks that work with an Apple LaserWriter will work with the Phaser 220i. Contact your computer or printer dealer for information.

Requirements for adding a hard disk

To connect an external disk you need these items:

- A SCSI peripheral cable for each disk. The printer uses a 50-pin connector.
- One SCSI cable terminator, unless your disk has an internal terminator.

The printer can support up to seven external disks connected at one time. When connecting a hard disk to the printer, follow these guidelines:

- You must turn on the disk(s) *before* you turn on the printer. Wait at least one minute after turning on the disk(s) before turning on the printer.
- The printer must always be at one end of the chain with a terminator at the other end.
- With multiple disks, each disk must have a unique SCSI ID number. Do not turn on the printer or disk *until each disk has a unique number*.
- With multiple disks, only one disk can contain a *Sys/Start* file.

Initialization -- Unless the disk is already formatted for operation with a PostScript printer, you have to initialize (format) the disk after connecting it to the printer. The Phaser 220 diskettes contain utilities to help you initialize the disk and download fonts to it. For instructions on how to use the utilities, refer to the manual *Phaser 220 Drivers and Utilities Printing Reference*.

SCSI ID number -- The printer's SCSI number is 7. Valid ID numbers for the external disk are **0** through **6**.

Termination -- The Phaser 220i has an internal terminator.

Note *If the Sys/Start file contains an error, the printer ignores the remainder of the file and may not start up as you expect it to.*

Start-up file -- You may load a start-up file called *Sys/Start* onto your external disk. You can use the *Sys/Start* file to customize printer operation (for example, set a port's default language or load fonts into the printer's memory).

When you turn on the printer, it executes that file if the printer's rear panel Switch 5 is in the *down* position. When Switch 5 is in the *up* position, the file does not execute.

Connecting one disk

Make sure that the computer, printer, and external disk are turned *off* before you connect or disconnect a SCSI cable.

1. Phaser 220i printer with a built-in SCSI terminator
2. SCSI port
3. External disk SCSI port
4. Terminator (not required if the disk has a built-in terminator)

Each disk must have a unique SCSI ID number. Do not turn on the printer or disk until each disk has a unique number.

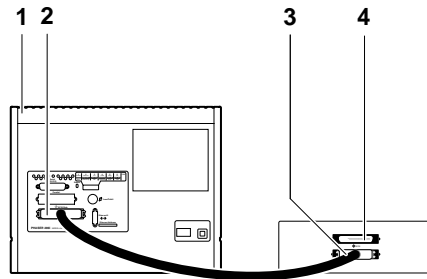

8869-39

Connecting multiple disks

Make sure that the computer, printer, and external disks are turned *off* before you connect or disconnect a SCSI cable.

1. Phaser 220i printer with a built-in SCSI terminator
2. SCSI port
3. External disks
4. Terminator (not required if the end disk has a built-in terminator; the middle disk must not have an internal terminator)

Each disk must have a unique SCSI ID number. Do not turn on the printer or disk until each disk has a unique number.

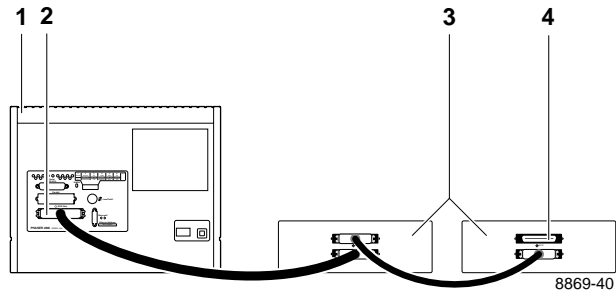

C

Moving Your Printer

Changing the line voltage

If you move the printer to a country that uses a line voltage different from the printer's factory setting, you can change the line voltage to the appropriate setting by using the line voltage selector switch.

Do not plug in the printer until the line voltage selector switch is properly set. For your safety, *do not* remove the cover from the printer. The line voltage selector switch is located next to the **On/Off** switch. Also, the new location may require a different power cord and fuse; see your dealer for details.

1. Line voltage selector switch.

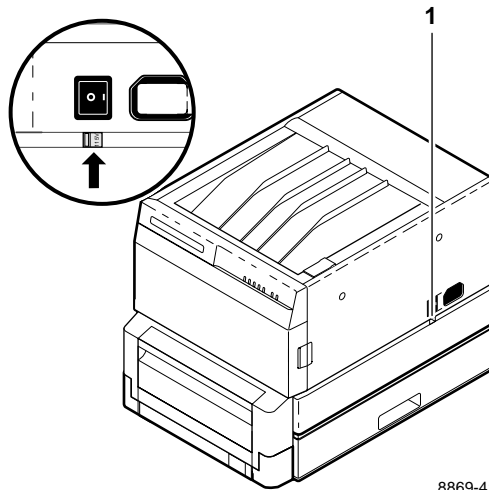

8869-41

Repacking your printer

1. Turn off the printer; remove all cords and cables.
2. Push the button to open the top cover.

Note *To keep your warranty valid, you must ship the printer in its Tektronix shipping box. Call Tektronix if you need a replacement box. Also, if you are returning the printer for service, call Tektronix for a return authorization number.*

3. Replace the packing material on both sides of the drum.
4. Remove the paper tray(s) and transfer roll. Pack these for shipping or storage.
5. Close the top cover. Secure the top and front covers with masking tape.

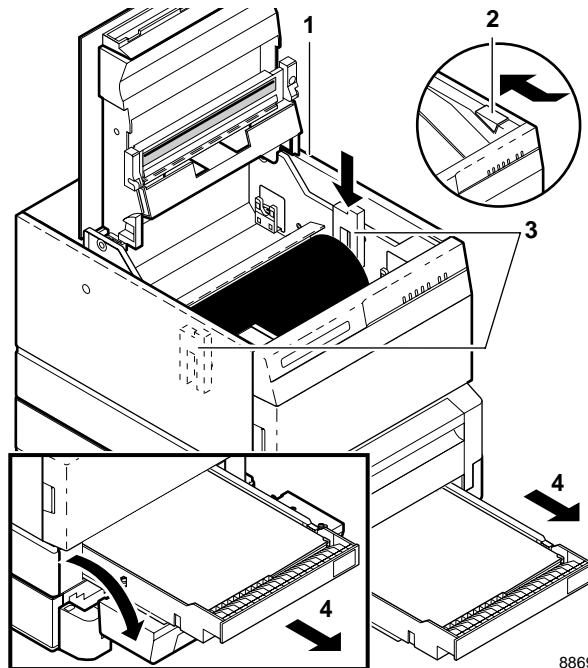

8869-11

6. If the printer has a lower tray assembly, make sure that the lower tray assembly cable is disconnected.
7. Lift the printer up and away from the lower tray assembly.
8. Repack the printer in the Tektronix shipping box. Keep the printer level when moving.

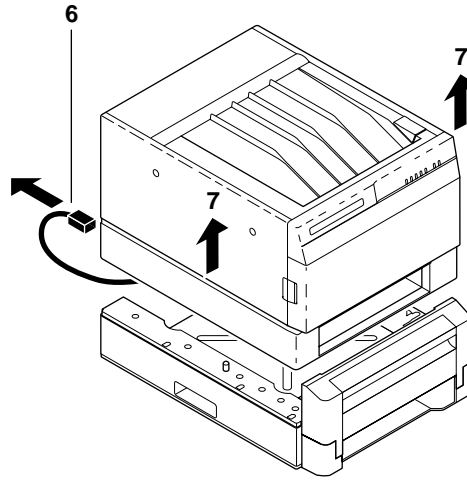

8869-42

C *Moving Your Printer*

D

Regulatory Information

Canadian EMC (Electromagnetic Compatibility) regulatory standards

- This digital apparatus does not exceed the Class B limits for radio noise emissions from digital apparatus set out in the Radio Interference Regulations of the Canadian Department of Communications.
- Le présent appareil numérique n'émet pas de bruits radioélectriques dépassant les limites applicables aux appareils numériques de la classe B prescrites dans le Règlement sur le brouillage radioélectrique édicté par le ministère des Communications du Canada.

Declaration of conformity

Tektronix, Inc.
Graphics Printing and Imaging Division
P.O. Box 1000
Wilsonville, Oregon 97070-1000 U.S.A.

declares, under our sole responsibility, that the products

Phaser 220i and Phaser 220e

to which this declaration relates, are in conformity with the following standard(s) or other normative document(s):

For the EC EN60950	Safety of Information Technology Equipment including Electrical Business Equipment
For the EC EN55022	Limits and methods of measurement of radio Interference characteristics of Information Technology Equipment
For Germany Vfg 243	Radio Interference suppression of Radio-Frequency Equipment for Industrial, Scientific, Medical (ISM) and similar purposes and Equipment used in Information Processing Systems; General License
VDE 0871/6.78 (Class B)	Radio Frequency Interference Suppression of Radio Frequency Equipment for Industrial, Scientific, and Medical (ISM) and Similar Purposes

following the provision of the

Low Voltage Directive 73/23/EEC, the Electromagnetic Compatibility
Directive 89/336/EEC, and the law governing the operation of
radio-frequency equipment (HfFG) 9 August 1949.

FCC Class B device (for 115 VAC equipment)

The equipment described in this manual generates and uses radio frequency energy. If it is not installed and used properly in strict accordance with Tektronix' instructions, it may cause interference with radio and television reception.

This equipment has been tested and verified to comply with the limits for a Class B digital device, pursuant to Part 15 of the FCC Rules. These limits are designed to provide reasonable protection against harmful interferences in a residential installation. This equipment generates, uses and can radiate radio frequency energy and, if not installed and used in accordance with the instructions, may cause harmful interference to radio communications. However, there is no guarantee that interference will not occur in a particular installation. If this equipment does cause harmful interference to radio or television reception, which can be determined by turning the equipment off and on, the user is encouraged to try to correct the interference by one of more of the following measures:

- Reorient or relocate the receiving antenna.
- Increase the separation between the equipment and receiver.
- Connect the equipment into an outlet on a circuit different from that to which the receiver is connected.
- Consult the dealer or an experienced radio/TV technician for help.

Warning *Changes or modifications not expressly approved by Tektronix can affect emission compliance and could void the user's authority to operate this product.*

Material Safety Data Sheet

Proper management of environmental resources protects the well-being of our employees, customers, shareholders, and the communities we are a part of worldwide.

Tektronix establishes and maintains sound environmental management practices to accomplish this goal and to assure compliance with the laws, regulations, and orders of the responsible governmental authorities wherever Tektronix and its subsidiaries operate.

Tektronix, Incorporated is complying with government regulations by providing Material Safety Data Sheets for our products.

*Graphics Printing and Imaging Division
Tektronix, Incorporated*

Section I – Product identification

Trade name and Tektronix part number:

<i>Black Transfer Roll</i>	016-1188-00
<i>3-Color Transfer Roll</i>	016-1262-00
<i>ColorCoat™ Transfer Roll</i>	016-1222-01

Product use: Used in Phaser 220 color printers.

Section II – Information on ingredients

Ingredients	CAS No.
Polyester film*	25038-59-9
Paraffin wax	8002-74-2
Coloring material	
Resin	

* Polyethylene Terephthalate

Hazardous Ingredients: None.

Section III – Hazards identification

Potential Health Effects:

Eyes: Non-irritating.

Skin: Non-irritating.

Inhalation: Not considered a route of exposure.

Ingestion: Not considered a route of exposure.

Section IV – First aid measures

This material is a coated film. No medical emergency is foreseen when product is used as intended.

Section V – Fire fighting measures

Flammable Properties:

Flash point: Not applicable.

Fire & explosion hazards: The film will burn when in contact with fire. Products of combustion include carbon dioxide, carbon monoxide, and water which are similar to combustion of other products found in an office setting.

Section VI – Accidental release measures

Spill Or Leak: This section is not applicable to this product, which is a dry film.

Section VII – Handling and storage

Handling: No special precautions necessary.

Storage: Store away from excessive heat.

Section VIII – Exposure control – personal protection

Exposure Guidelines: No PEL or TLV established.
Engineering Controls: No special controls necessary.
Eye Protection: None needed.
Skin Protection: None needed.

Section IX – Physical and chemical properties

Appearance: Coated, flexible film.
Odor: None.
Solubility: Not soluble in water.

Section X – Stability and reactivity

Stability: Stable.
Incompatibility With Other Materials: None expected.
Hazardous Polymerization: Not applicable.

Section XI – Toxicological information

No data available.

Section XII – Ecological information

No data available.

Section XIII – Disposal considerations

Dispose in accordance with all Federal, State or Local regulations. This film is not considered a hazardous waste under RCRA 40 CFR 261.

Section XIV – Transport information

D.O.T.: Not a hazardous material for DOT shipping.

Section XV – Regulatory information

SARA Title III:

311/312 Hazard Categories: None applicable.

313 Reportable Ingredients: None.

California Prop. 65: None of the components of this film appear on the California Proposition 65 list of chemicals known to cause cancer or reproductive toxicity.

Canadian WHMIS: The film meets the requirements of a “manufactured article” under Canadian Workplace Hazardous Materials Information System. and therefore no MSDS or label is required.

TSCA: All components of this film are included in the Toxic Substances Control Act inventory as verified by our suppliers.

OSHA: This film meets the definition of an article under 29 CFR 1910.1200 Hazard Communication and therefore it is exempt from its requirements. We are supplying this data sheet as a courtesy to our customers.

Section XVI – Other information

Original preparation date: 11/19/93 R.C.

Tektronix, Incorporated
P.O. Box 500
Chemical Documentation
Mail stop 22-069
Beaverton, Oregon 97077
Printer information: 1-800-835-6100
MSDS information: (503) 627-7255
Emergency: (503) 627-7255

D *Regulatory Information*

Index

Numerics

4511A 2-18

A

AppleTalk 2-13

automatic language switching 3-14

AutoSelect 3-8

B

baud rate, setting A-3

black and white 6-11

C

Chooser

printer doesn't appear 6-7

select printer 3-1

cleaning 4-1

drum 4-12

exit rollers 4-13

kit 4-3

paper-feed rollers 4-5

paper-pick rollers 4-6 to 4-9

thermal head 4-4

transfer roll sensor pad 4-10

color correction 3-11

TekColor 3-2, 3-3

ColorCoat 5-2

COM port, setting up 2-29

configuration page 6-13

connecting power 2-19

COVER indicator 7-6

customer support 6-14

D

disk, see *hard disk*

DOS 2-25

downloading fonts 3-13

driver

Macintosh 2-26

Windows 2-23

drum, cleaning 4-12

E

enhanced mode 3-10

ERROR indicator 7-6

error messages, on the startup page 6-12

Ethernet 2-12, 2-18

problems 6-7

exit rollers, cleaning 4-13

F

flagging, setting A-3

font disk, see *hard disk*

font upgrade 3-13

fonts 3-12

front panel indicators 7-6

H

HAL — Highly Automated Library 6-14

hard disk B-3

connecting multiple B-6

connecting single B-5

guidelines B-3

initialization B-4

Sys/Start file B-4

high-resolution mode 3-10

HP-GL 1-2

setting parameters 3-15

using 3-15

I

image area 3-6, 3-7, 3-16

image prints over perforations 6-9

image shifts 6-9

image size 3-6, 3-7, 3-16

indicators
 at power-up 2-20
 front panel 7-6
 rear panel 2-21
installation
 connecting the printer 2-12 to 2-22
 installing drivers 2-23 to 2-26
 setting up PC ports 2-29
 setting up the printer 2-6 to 2-11
ISO 1-1

J

JAM indicator 7-6

L

language switching 3-14
line voltage selector switch C-1
line voltage, changing C-1
loading paper 2-8
loading transparencies 2-8
LocalTalk
 connecting 2-13
 problems 6-7
lower tray assembly 2-5
 using two paper trays 3-8
LPT port, setting up 2-28

M

margins 3-6, 3-7
 incorrect 6-9
 too big with perforated paper or
 transparencies 6-9
MEDIA indicator 7-6
Microsoft Windows 2-23
MODE command (DOS) 2-29
modes 3-10
moving the printer C-2

O

ordering supplies 1-2, 5-1

P

page sizes 3-7
pages sizes 3-6
paper
 handling 5-6
 jams 6-2 to 6-4
 loading 2-8
 picking errors 6-8
 plain, see *plain paper*
paper tray 2-8
 for plain paper 5-3
 using two trays 3-8
paper-feed rollers, cleaning 4-5
paper-pick rollers, cleaning 4-6 to 4-9
parallel port, computer, see *LPT port*
parallel port, printer
 connecting 2-15
 signals A-1
parity, setting A-3
PCL5 1-2
 fonts 3-13
Phaser 220 drivers and utilities diskettes 2-23
 Macintosh driver 2-26
 screen fonts 3-13
 SCSI disk initialization B-4
 to control automatic language
 switching 3-14
 to download fonts 3-13
 to generate the configuration page 6-13
 Windows driver 2-23
 workstations 2-27
plain paper
 paper tray 5-3
 recommended paper types 5-4
 transfer roll 5-2

- ports, computer 2-28, 2-29
- ports, printer
 - Ethernet 2-12, 2-18
 - LocalTalk 2-13
 - parallel 2-15, A-1
 - serial 2-16, A-3
 - speed 3-16
- PostScript fonts 3-12
- PostScript language files, to change serial port settings A-3
- POWER indicator 7-6
- power, connecting 2-19
- power-up 2-20
- print area 3-6, 3-7, 3-16
- print count 4-2
- print modes 3-10
- print size 3-6, 3-7, 3-16
- printer name 3-1
- printing
 - from a Macintosh 3-1
 - from a PC (DOS) 3-4
 - from a PC (Windows) 3-3
 - from a workstation 3-5
 - time 3-16
 - timeout 6-7

R

- READY indicator 7-6
- rear panel
 - indicator 2-21
 - switches 3-11
- registration page 2-22
- repacking the printer C-2
- resident fonts 3-12, 3-13
- RIBBON indicator 7-6

S

- sample prints 2-21, 2-27

- screen fonts, Macintosh 3-13
- SCSI 1-2
 - ID number B-4
 - port 2-12
 - termination B-4
- SCSI disk, see *hard disk*
- self-tests 2-20
- serial port, computer, see *COM port*
- serial port, printer
 - connecting 2-16
 - setting up A-3
 - signals A-4
- service 6-14
- specifications A-5
- spots on prints 6-10
- standard mode 3-10
- startup page 2-22
 - disabling 2-27
 - prints when disabled 6-12
 - reports error message 6-12
- streaks on prints 6-10
- supplies, ordering 1-2, 5-1
- switches
 - color correction 3-11
- Sys/Start file B-4

T

- technical support 6-14
- TekColor 3-2, 3-3
- TEST button 6-5
- thermal head, cleaning 4-4
- timeout 6-7
- transfer roll
 - installing 2-7
 - jams 6-1
 - plain paper 5-2
 - removing 5-7
 - storage 5-6

- transfer roll sensor pad, cleaning 4-10
- transparencies
 - handling 5-6
 - jams 6-2 to 6-4
 - loading 2-8
 - picking errors 6-8
- troubleshooting
 - cut off images 6-9
 - frequent paper-picking errors 6-8
 - image prints in black and white instead of color 6-11
 - image prints over perforations 6-9
 - image shifts or margins incorrect (Macintosh) 6-9
 - margins too big with perforated paper or transparencies 6-9
 - off-set images 6-9
 - print job does not finish 6-7
 - printer doesn't appear in the Chooser 6-7
 - printer not operating 6-5
 - prints have dull, faded colors and significant dropout 6-10
 - prints show streaks or spots 6-10
 - READY light blinks, but file does not print 6-7
 - startup page prints when disabled 6-12
- TrueType fonts 3-13
- turning on the printer 2-19

U

- upgrade kits B-1

W

- Windows 2-23
- workstations 2-27, 3-5